

User's manual

LC series

Title: LC SERIES
 Date: April 2008
 ProdID: R5976934
 Revision: 08

This manual is divided into 13 chapters:

	main issue	update
Warranty statement		Rev. 05
chapter 1		
chapter 2		Rev. 03: new dimensions LC-47, rev. 06: new drawings
chapter 3		
chapter 4		
chapter 5		OSD update, rev. 06: OSD update (SDI/HD-SDI interface)
chapter 6		
chapter 7		Rev. 09: Add: SDI/HD-SDI interface
chapter 8		Rev. 03: new dimensions LC-47, rev. 06: Add: SDI/HD-SDI interface Rev. 07: new dimensions LCx-42, LCx47
chapter 9		Revised timing, rev. 06: SDI/HDSI timings
chapter 10		
chapter 11		Rev. 03, FCC statement
chapter 12	-	Rev. 06, installation of accessories
chapter 13	-	

- new: The corresponding chapters are new or completely revised.
- corr.: Passages of the corresponding chapter were corrected; see modification bars.
- add.: Passages of the corresponding chapter were added; see modification bars.

Document History

Modifications which result in a new version are indicated by a vertical bar.

Trademarks

Brand and product names mentioned in this manual may be trademarks, registered trademarks or copyrights of their respective holders. All brand and product names mentioned in this manual serve as comments or examples and are not to be understood as advertising for the products or their manufacturers.

Copyright © 2005-2008 by Barco

Die Weitergabe sowie die Vervielfältigung aller Unterlagen, die von uns überlassen werden, deren Verwertung und Mitteilung ihres Inhaltes an Dritte ist nicht gestattet, soweit dies nicht ausdrücklich zugestanden ist. Urheberrechte, insbesondere auch solche an Software, werden nur insoweit übertragen, als es für die Erreichung des speziellen Vertragszwecks erforderlich ist. Zuwiderhandlungen können zu Schadensersatz verpflichten. Alle Rechte aus der Erteilung eines Patents oder der Eintragung eines Gebrauchsmusters verbleiben bei uns.

Copyright © 2005-2008 by Barco

All rights reserved. No part of this document may be copied, reproduced or translated. It shall not otherwise be recorded, transmitted or stored in a retrieval system without the prior written consent of Barco.

WARRANTY STATEMENT

Hardware warranty

The warranty period commences at the date of signature of the Certificate of Installation and Operation or as soon as the purchaser, customer or any other party occupies or operates the system, or 3 months after shipping in case no certificate of installation and Operation is provided.

- The Seller warrants the equipment manufactured by the Seller against defects in workmanship and material, under normal use and in accordance with its specifications, during the period of 24 months from the aforementioned date. Any part of the equipment which is wholly manufactured by third parties, is guaranteed under the conditions of such manufacturer and no separate warranty is given in respect thereof by the Seller.
- In the particular case of LCD displays, the warranty does not apply to the case of image retention phenomena (shadows, dark lines and other image artifacts), that may result from a usage outside of the following specification: in the course of 24 hours, the monitor can be used for maximum 2 shifts of 8 hours, with minimum 1 hour of relaxation between the shifts.
- In the event of a defect in workmanship or material, the Seller will be obliged, at its choice and best effort base, to replace or repair the defective equipment. The replacement part will be in good working order and at least functionally equivalent to the item replaced.
- The warranty does not apply when the cause of the failure occurs after delivery of the equipment to the Purchaser and results from abnormal conditions of operation, unauthorized access, improper use, unauthorized modification, lack of normal maintenance or unauthorized attempts to repair the equipment. See also Pre installation requirements and conditions of use BCD system. A failure to follow these requirements can result in delay and additional costs that will be invoiced to the purchaser.
- The Purchaser must notify the Seller of any complaint within eight days of discovery of any alleged defect. Failure by the Purchaser to so notify the Seller will relieve the Seller of its obligations under this article.
- The foregoing warranty will not apply if any payment remains outstanding from the Purchaser to the Seller.
- All items, parts or components which are replaced by the Seller under warranty or otherwise shall become the property of the Seller. All defective parts need to be sent back to the Seller.
- The replacement parts are free of charge during the warranty period.
- The Seller will ship the replacement parts to the Purchaser on a CIF base. At the same time the Seller will issue a RAN number for returning the defective parts.
- Traveling and Lodging of the service engineer will be invoiced to the Purchaser according to the Time & Material Pricing rules of the Seller.
- On site labor of the service engineer will be invoiced to the Barco National Organization or Sales Partner according to the Time & Material Pricing rules of the Seller.
- The remedies described above are Purchaser's sole remedies in the event of any breach of the warranty provided above.
- Consumables (such as lamps, dust filters, ...) are excluded from warranty.
- The warranty period of repairs and spare parts is 3 months, or at minimum the original warranty period of the system.
- The seller does no warrant uninterrupted or error-free operation of the installation
- The foregoing warranty is in lieu of all other warranties, whether oral, written, express, implied or statutory. No implied or statutory warranties of merchantability or fitness for a particular purpose shall apply and all warranties, conditions or other terms implied by statute or common law are hereby excluded.

Software warranty

The Seller makes no warranties with respect to the software and technical information and, such items are provided to the Purchaser on an "as-is" basis without warranty of any kind, including the warranties of merchantability and fitness for a particular purpose.

- The Purchaser acknowledges and agrees that the software provided by the Seller to the Purchaser in an unmodified form is designed to operate with the hardware identified in the Certificate of Installation and Operation, provided (i) the hardware is unmodified and (ii) the software, as unmodified, operates in conjunction with the proper computer equipment as designated in the Special Conditions.
- The Purchaser agrees to indemnify, defend and hold harmless the Seller from and against all claims, liabilities, losses, damages and costs and expenses arising out of or resulting from the combination or integration of the hardware and/or software with any item of any kind not furnished by the Seller.

Revision sheet

To:

- **Barco Control Room GmbH**
An der Rossweid 5, D-76229 Karlsruhe
Phone: +49-721-6201-0, Fax: +49-721-6201-298
E-mail: docu.bcd.de@barco.com, Web: www.barcocontrolrooms.de

From: _____

Date: _____

Please correct the following points in this documentation:

page	wrong	correct

Contents

1 Preliminary Remarks	1-1
1.1 How this manual is organized	1-2
1.2 Styles and symbols	1-3
1.3 Safety information.....	1-4
1.3.1 Safety on installation.....	1-4
1.3.2 Safety on servicing	1-7
1.3.3 Safety on shipping	1-8
1.3.4 Precautions	1-8
1.3.5 Malfunction or Trouble	1-8
1.3.6 Unpacking of devices.....	1-8
1.3.7 Modification of devices	1-9
1.3.8 Disposal or handing over to a new owner	1-9
1.3.9 Exemptions.....	1-9
2 Unpacking and installation.....	2-1
2.1 Unpacking	2-2
2.2 Installation	2-3
2.2.1 Accessories	2-3
2.2.2 Mounting of the table stand (optional).....	2-3
2.2.3 Dimensions of the 42" monitor:.....	2-5
2.2.4 Dimensions of the 47" monitor:.....	2-6
2.3 Examining the monitor.....	2-7
2.3.1 Front view	2-7
2.3.2 Side view.....	2-7
2.3.3 Rear view	2-8
2.4 Cabling	2-9
2.5 Switching on and off	2-9
2.6 Inserting batteries into the Infrared remote control unit.....	2-10
3 Design and function.....	3-1
3.1 Display of choice.....	3-2
3.2 Technology.....	3-3
3.2.1 Principle of LCD technology.....	3-3
4 Controlling.....	4-1
4.1 General.....	4-2
4.1.1 The push buttons	4-2
4.1.2 The IR remote control unit	4-3
4.2 Terminology of the RCU controls	4-4
4.3 Functions available with the IR Remote Control Unit.....	4-5
4.3.1 Displaying a monitor address	4-5
4.3.2 Baud rate setting	4-5

4.3.3 The function keys.....	4-6
4.3.4 Picture controls with direct access.....	4-6
4.3.5 Audio controls with direct access.....	4-6
5 The On Screen Display (OSD)	5-1
5.1 General.....	5-2
5.1.1 Navigation and adjustment.....	5-3
5.2 Activating the OSD.....	5-4
5.3 The signal menu (first and second input)	5-6
5.3.1 Display.....	5-7
5.3.2 Position.....	5-11
5.3.3 PIP control.....	5-14
5.3.4 Combination of signals for main image and PiP/PaP	5-17
5.3.5 Image	5-18
5.3.6 Color	5-26
5.4 OSD setting menu.....	5-29
5.4.1 Vertical	5-30
5.4.2 Horizontal.....	5-30
5.4.3 Blend	5-30
5.4.4 Time out	5-31
5.4.5 OSD Zoom.....	5-31
5.5 Audio setting menu.....	5-32
5.5.1 Volume	5-33
5.5.2 Balance.....	5-33
5.5.3 Bass	5-33
5.5.4 Treble	5-34
5.6 Display parameter setting menu.....	5-35
5.6.1 Set display address.....	5-36
5.6.2 Baud rate.....	5-36
5.6.3 Light Sensor	5-37
5.6.4 Lower brightness level	5-37
5.6.5 Ambient light threshold	5-37
5.6.6 Auto Source Selection.....	5-38
5.7 Reset menu.....	5-39
5.7.1 Factory Reset	5-40
5.8 Input Signal Selection.....	5-41
5.8.1 Input selection with the function key F1.....	5-44
6 Maintenance and servicing	6-1
6.1 Cleaning	6-2
7 Technical data 42" version (LCN-42, LCS-42)	7-1
7.1 General data	7-1
7.2 LCD panel	7-1
7.3 Electrical data	7-1
7.4 Operating conditions	7-2

7.5 CCFL (Cold Cathode Fluorescent Lamp) characteristics (ambient temperature (25 ±2)°C).....	7-2
7.6 Interfaces	7-2
7.6.1 Video IN (Composite Video)	7-2
7.6.2 S-Video	7-3
7.6.3 Component Video (mini DIN 8 pin)	7-3
7.6.4 SDI/HDSDI IN/OUT (BNC) (LCS-42 only)	7-5
7.6.5 DVI	7-5
7.6.6 RGB IN (D-Sub 15 pin)	7-6
7.6.7 RS232 IN.....	7-6
7.6.8 RS232 OUT.....	7-7
7.7 Factory settings	7-7
8 Technical data 47" version (LCN-47, LCS-47)	8-1
8.1 General data	8-1
8.2 LCD panel	8-1
8.3 Electrical data	8-1
8.4 Operating conditions	8-2
8.5 CCFL (Cold Cathode Fluorescent Lamp) characteristics (ambient temperature (25 ±2)°C).....	8-2
8.6 Interfaces	8-2
8.6.1 Video IN (Composite Video).....	8-2
8.6.2 S-Video	8-3
8.6.3 Component Video	8-3
8.6.4 SDI/HDSDI IN/OUT (BNC)	8-5
8.6.5 DVI	8-5
8.6.6 RGB IN (D-Sub 15 pin).....	8-6
8.6.7 RS232 IN.....	8-6
8.6.8 RS232 OUT.....	8-7
8.7 Factory setting	8-8
9 Compliant timing	9-1
9.1 SDI input signals	9-2
9.2 HD-SDI input signals	9-3
10 Troubleshooting	10-1
10.1 Faults.....	10-2
10.2 Contact	10-3
11 Compliance statement.....	11-1
11.1 FCC Compliance statement	11-1

12 Accessories	12-1
12.1 Required tools	12-1
12.2 Table stand	12-2
12.2.1 Scope of delivery	12-2
12.2.2 Installation	12-3
12.2.3 Dimensions	12-4
12.2.4 Height adjustment.....	12-5
12.3 Screen bracket (adapter plate).....	12-6
12.3.1 Scope of delivery	12-6
12.3.2 Installation	12-7
12.4 Fixed wall mount.....	12-8
12.4.1 Scope of delivery	12-8
12.4.2 Installation	12-9
12.4.3 Dimensions	12-10
12.4.4 Wall pattern	12-11
12.5 Tilttable wall mount	12-12
12.5.1 Scope of delivery	12-12
12.5.2 Installation	12-13
12.5.3 Dimensions	12-14
12.5.4 Tilting	12-15
12.6 Short ceiling mount	12-16
12.6.1 Scope of delivery	12-17
12.6.2 Installation	12-18
12.6.3 Dimensions	12-20
12.6.4 Tilting	12-21
12.7 Long ceiling mount.....	12-22
12.7.1 Scope of delivery	12-23
12.7.2 Installation	12-24
12.7.3 Dimensions	12-26
12.7.4 Tilting	12-27
13 Contact	13-1

1 Preliminary Remarks

This manual describes unpacking, installation, cabling and controlling of the monitors of Barco's LC series.

The monitors of Barco's LC series are based on Super MVA TFT LCD technology and feature bright and wide images with clear contrast.

The LCD panels have 1920x1080 pixels (HD resolution) to allow extreme fine pictures at 16.7 millions colors.

The monitors provide a set of interfaces to connect any analog video and analog and digital RGB data .

All settings can easily be accessed and modified by means of the Infrared remote control unit and the OnScreenDisplay.

RS232 remote control is also possible.

The monitors are available with a screen diagonal of 42" and 47".

LCN-47	Monitor with a screen diagonal of 47inch, Super MVA TFT LCD technology, HD resolution (1920x1080 pixels), aspect ratio 16:9
LCS-47	Monitor with a screen diagonal of 47inch, Super MVA TFT LCD technology, HD resolution (1920x1080 pixels), aspect ratio 16:9, HD-SDI input
LCN-42	Monitor with a screen diagonal of 42inch, Super MVA TFT LCD technology, HD resolution (1920x1080 pixels), aspect ratio 16:9
LCS-42	Monitor with a screen diagonal of 42inch, Super MVA TFT LCD technology, HD resolution (1920x1080 pixels), aspect ratio 16:9, HD-SDI input

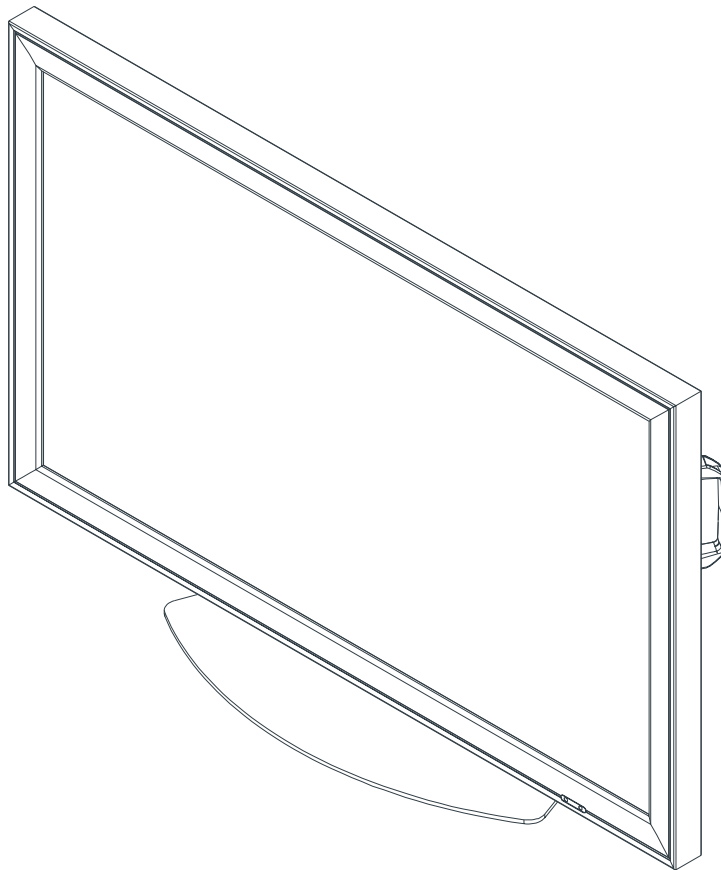

1.1 How this manual is organized

This manual is divided into 13 chapters:

- **Preliminary remarks**
explains the structure of the manual itself and the used typographic styles and symbols. Safety information is provided concerning the monitors of Barco's LC series.
- **Unpacking and Installation**
gives instructions how to unpack the monitors and general installation requirements
- **Design and function**
provides a technical description of the equipment listing the fundamental characteristics and functional principles. Knowledge of this section is not absolutely essential for operation.
- **Controlling**
explains how the monitors are controlled
- **The On Screen Display**
explains the commands of the menus
- **Maintenance and servicing**
explains how the equipment can be serviced.
- **Technical data of the 42" versions**
provides tabular overviews about the technical details of the monitor LCN-42 and LCS-42
- **Technical data of the 47" versions**
provides tabular overviews about the technical details of the monitor LCN-47 and LCS-47
- **Compliant timing**
lists the compliant timing of the monitor
- **Trouble shooting**
gives hints in case the monitor does not work
- **Compliance statement**
Includes the FCC statement
- **Accessories**
lists the available accessories and their installation
- **Contact**
lists address details of the help desk

Chapters, pages, and tables are numbered separately. Chapters are indicated by a »point syntax«, e. g. **4.2.3**, pages and tables by a »dash syntax«, e. g. **2-1**.

1.2 Styles and symbols

The typographic styles and the symbols used in this document have the following meaning:

Bold	Labels, menus and buttons are printed in Bold font.
Condensed	Links to both other chapters of this manual and to sites in the Internet are printed condensed . In the on-line version of this manual all hyperlinks appear teal .
Courier	Names of files and parts from programs are printed in the Courier font.
Courier bold	Inputs you are supposed to do from the keyboard are printed in Courier bold font.



If you do not heed instructions indicated by this symbol there is a risk of damage to the equipment!



If you do not heed instructions indicated by this symbol there is a risk of electrical shock and danger to personal health!



If you do not heed instructions indicated by this symbol there is a risk of damage to parts, which are sensitive toward electrostatic charge!



If you do not heed instructions indicated by this symbol there is a risk to get harmed by sharp objects!



If you do not heed instructions indicated by this symbol there is a risk that parts may explode!



If you do not heed instructions indicated by this symbol there is a risk that hot parts impact persons or objects!



The sheet icon indicates additional notes.



Next to this icon you find further information.



This hand marks tips.



Next to this icon you find important notes.

1.3 Safety information

This section describes safety precautions which must be observed when installing a product from Barco.

Safety standards

The safety standards of information technology equipment impose important requirements on the use of safety critical components, materials and isolation, in order to protect the user or operator against the risk of electric shock and energy hazard, and having access to live parts.

Safety standards also impose limits to the internal and external temperature rises, radiation levels, mechanical stability and strength, enclosure construction and protection against risk of fire.

Simulated single fault condition testing ensures the safety of the equipment to the use even when the equipment's normal operation fails.

General safety instructions

- All the safety and operating instructions should be read before using this unit.
- The operating instructions manual should be retained for future reference.
- All warnings on the device and in the documentation manuals should be adhered to.
- All instructions for operating and use of this equipment must be followed precisely.
- All local installation codes should be adhered to.



Installation and preliminary adjustments should be performed by qualified Barco personnel or authorized Barco service dealers.

1.3.1 Safety on installation



Check the power rating on your outlet before connecting the devices to the wall outlet or to a power strip. Contact your facilities manager or a qualified electrician if you are not sure what type of power is supplied to your building.



The devices are designed to operate with single-phase power systems having a grounded neutral conductor. To reduce the risk of electrical shock, do not plug into any other type of power system.

A. Mains lead (AC Power cord) with CEE 7 plug:

The colors of the mains lead are colored in accordance with the following code:

Green-and-yellow:	Earth (safety earth)
Blue:	Neutral
Brown:	Line (live)



B. Power cord with NEMA 15-5 plug:

The wires of the power cord are colored in accordance with the following code:

Green or green/yellow:	Ground
White or blue:	Neutral
Black or brown:	Line (live)

- Do not allow anything to rest on the power cord. Do not locate this product where persons will walk on the cord.
- To disconnect the cord, pull it out by the plug. Never pull the cord itself.
- If an extension cord is used with this product, make sure that the total of the ampere ratings on the products plugged into the extension cord does not exceed the extension cord ampere rating. Also make sure that the total of all products plugged into the wall outlet does not exceed 15 amperes.
- Never push objects of any kind into this product through cabinet slots as they may touch dangerous voltage points or short out parts that could result in a risk of fire or electrical shock.
- Never spill liquid of any kind on the product. Should any liquid or solid object fall into the cabinet, unplug the set and have it checked by qualified service personnel before resuming operations.
- Lightning - For added protection for this video product during a lightning storm, or when it is left unattended and unused for long periods of time, unplug it from the wall outlet. This will prevent damage to the monitor due to lightning and AC power-line surges.



Warning: Do not place flammable or combustible materials near the monitor!

Transportation

- Any transportation of the unopened unit in its packaging should be done by two persons.
- In transportation or storage of products in original packing, NEVER stack more than the number stated on the carton box. This warning is also indicated on the side of the card box.
- For transportation or storage, observe the warnings and instructions on the side of the card box.

Nearby equipment

If air conditioning ducts or lamps, etc. are located near the installation site, the attendant dust, extreme temperatures, humidity, and condensation may become sources of trouble. Please take sufficient steps to avoid this.

Safety locations

Do not install the unit where it may be easily touched or leaned against. Avoid locations subject to high vibrations or severe impacts. Do not install the unit where it is exposed to humidity, oil, smoke or excessive dust.

Mechanical stress.

Please be careful not to apply strong mechanical stress (shock, drop) to the LCD module. Such stress may cause break of screen glass and lamp or may be the cause for failure.

Pressure to screen surface.

Please be careful not to apply strong pressure to the screen surface. Such pressure may cause scratches at the surface or may be the cause of failure.

Protection against scratch.

Please be careful not to hit, press or rub the screen surface with hard material like tools. In addition, please do not put heavy or hard material on the screen surface, and do not stack monitors. Polarizer at the front surface can be easily scratched.

Temperature dependence of the display.

Response speed (optical response) of the LCD display is dependent on temperature. Under low temperature, response speed is slower. Also brightness and chromaticity change slightly depend on temperature.

Image retention

Displaying the same pattern for a long time may cause image sticking, vertical dark lines or other forms of image artifacts. This is a common phenomenon of all LCD displays. It disappears after some time if the pattern is changed, or the monitor is switched off. However, image retention is not subject of warranty.

For more information contact Barco for a white paper on this topic.

Lightning conditions

Consider existing lightning and sunlight angles when creating the installation layout. Extremely bright lightning can reduce the visibility and the quality of the displayed image.

In extremely bright surroundings, adjusting screen intensity may not result in perceptibly brighter images. Keep in mind that extreme intensity settings can reduce system service life.

Barco products are designed and manufactured to meet the most stringent safety regulations. Exposing flammable or combustible materials into close proximity of this device could result in the spontaneous ignition of that material, resulting in a fire. For this reason, it is absolutely necessary to leave an "exclusion zone" around all external surfaces of the monitor whereby no flammable or combustible materials are present. The exclusion zone must be not less than 10 cm (4"). Do not cover the monitor with any material while it is in operation.

Keep flammable and combustible materials away from the monitor at all times. Mount the monitor in a well ventilated area away from sources of ignition and out of direct sun light. Never expose this product to rain or excessive moisture. In the event of fire, use sand, CO₂ or dry powder fire extinguishers; never use water on an electrical fire.

Always have service performed on this product by authorized Barco service personnel. Always insist on genuine Barco replacement parts. Never use non-Barco replacement parts as they may degrade the safety of this device.

Use only the power cord supplied with your device. While appearing to be similar, other power cords have not been safety tested at the factory and may not be used to power the display. For a replacement power cord, contact your dealer.

Slots and openings in the cabinet and the sides are provided for ventilation; to ensure reliable operation of the device and to protect it from overheating, these openings must not be blocked or covered. This product should never be placed near or over a radiator or heat register. This product should not be placed in a built-in installation or enclosure unless proper ventilation is provided.

1.3.2 Safety on servicing

Do not attempt to service this device yourself, as opening or removing covers may expose you to dangerous voltage potential and risk of electric shock! Refer all monitor service to a qualified Barco service center.

Adjust only those controls that are covered by the operating instructions since improper adjustment of the other controls may result in damage and will often require extensive work by a qualified technician to restore the product to normal operation.

Call for service in the following conditions:

- When the power cord or plug is damaged or frayed.
- If liquid has been spilled into the device.
- If the product has been exposed to rain or water.
- If the product does not operate normally when the operating instructions are followed.
- If the product has been dropped or the cabinet has been damaged;
- If the product exhibits a distinct change in performance, indicating a need for service.

Replacement parts

When replacement parts are required, be sure the service technician has used original Barco replacement parts or authorized replacement parts which have the same characteristics as the Barco original part. Unauthorized substitutions may result in degraded performance and reliability, fire, electric shock or other hazards. Unauthorized substitutions may void warranty.

Safety check

Upon completion of any service or repairs to this unit, ask the service technician to perform safety checks to determine that the unit is in proper operating condition.

Protection

Please do not disassemble or modify the LCD module to avoid the possibility of electric shock, damage of electronic components, scratch at display surface and invasion of foreign particles. In addition, such activity may result in fire accident due to burning of electronic component.



The LCD module disassembled or modified by customer is out of warranty.

Please be careful in handling of display with broken glass. When the display glass breaks, please pay attention not to injure your fingers. The display surface has the plastic film attached, which prevents dispersion of glass pieces; however touching broken edge will injure your fingers. Also the lamp (Cold Cathode Fluorescent Lamp) is made of glass, therefore please pay attention in the same way.

Please do not touch the fluid flown out of broken display glass. If the fluid should stick to hand or clothes, wipe off with soap or alcohol immediately and then wash it with water.



If the fluid should get in your eyes, wash your eyes immediately with pure water for more than 15 minutes and then consult the doctor.



The lamp contains mercury inside. Please follow the regulations or rules established by local authorities at its disposal..

1.3.3 Safety on shipping

Original shipping package

Save the original shipping packing material; they will come in handy if you ever have to ship one of your installed modules. For maximum protection, repack your set as it was originally packed at the factory.

1.3.4 Precautions

For your own protection, observe the following safety precautions!

- Observe all warnings and instructions printed on the devices!
- Check that the voltage and frequency of your power supply match those printed on the device label with the rated electrical values!
- Servicing not explicitly mentioned in this manual should never be carried out by unauthorized personnel!
- Some parts of the body are hot during operation. Please be careful.
- In case of moving long-distance, wrap the unit with blanket to avoid damages. Be careful not to bump the unit.
- Do not spray

Unused for long periods of time

For added protection for this video product during a lightning storm, or when it is left unattended an unused for long periods of time, unplug it from the wall outlet. This will prevent damage to the LCD module due to lightning and AC power-line surges

1.3.5 Malfunction or Trouble

Trouble	take the following steps	risk of
Smoke or peculiar smells comes from the unit	Remove the power plug from the outlet immediately! Make sure that the smoke or smell has stopped, then contact your dealer for inspection	fire or an electric shock
No picture or sound	Remove the power plug from the outlet immediately! Contact your dealer for inspection	fire or an electric shock
Water is spilled or objects are dropped inside the unit	Remove the power plug from the outlet immediately! Contact your dealer for inspection	fire or an electric shock
The unit is dropped or the cabinet is damaged	Remove the power plug from the outlet immediately! Contact your dealer for inspection	fire or an electric shock
The power cord or plug is damaged or becomes hot	Power off the unit with the power switch on the rear side. When the power plug has cooled down, remove the power plug from the wall outlet! Contact your dealer for inspection	fire or an electric shock

1.3.6 Unpacking of devices

Note advises on the packaging for unpacking!

Please refer to chapter [2 Unpacking and installation](#)

1.3.7 Modification of devices

Mechanical or electrical modifications others than described in this manual must not be made to the devices. Barco is not liable for damages resulting from modified devices.



Only authorized personnel should carry out other maintenance work not explicitly mentioned in this user's manual!

Never open the case of the monitor without first disconnecting the power supply cord! Measurements and tests with an opened device may be carried out only in the factory or by specially trained personnel, due to the dangers of electrical shock.

1.3.8 Disposal or handing over to a new owner

- It is recommended to initialize the unit by resetting it to factory's default, cf. [5.7.1 Factory Reset](#).
- Do not mix with other general waste.
- Do not dispose the LCD monitor in waste treated by a waste treatment center.



The lamp contains mercury inside. Please follow the regulations or rules established by local authorities at its disposal..

1.3.9 Exemptions

- This monitor is not liable for any damage caused by natural disaster (such as earthquake, thunder, etc.), fires, acts by third parties, accidents, owner's intentional misuse and fault, or uses in other improper conditions.
- This monitor is not liable for incidental damages (such as profit loss or interruption in business, modification or erasure of record data, etc.) caused by use or inability to use of this product.
- This monitor is not liable for any damage caused by neglect of the instructions described in the owner's manual.
- This monitor is not liable for any damage caused by misuse or malfunction through simultaneous use of this product and the connected equipment or software.
- This monitor is not liable for any damage caused by neglect of the instructions described about the installation stand in the owner's manual.
- This monitor is not liable for any damage caused by improper installation.

2 Unpacking and installation

2.1 Unpacking

The monitor is surrounded with foam for transportation protection and packed into a card box. Banding and fastening clips secure the package.

To unpack the monitor,

- Release the fastening clips
- Remove the banding
- Take the monitor out
- Remove the foam.



For later shipment, it is recommended to store the original packaging and to re-use it.

The following components are included in the delivery:

- The monitor itself
- 1 pc power cord (European, with CEE7 power plug)
- 1 pc power cord (American, with NEMA 15-5 (ANSI 73.11) power plug)
- 1 pc user's manual
- 1 pc Infra red remote control unit
- 1 pc RCA jack
- 1 pc DVI-D 24 pin cable
- 1 pc D-Sub 15 pin cable
- 1 pc S-Video Mini Din 4 pin cable
- 1 pc cable adapter Mini Din 8 pin to 3xRCA jack (for component video)

2.2 Installation



Installation and preliminary adjustments should be performed by qualified Barco personnel or authorized Barco service dealers.

Installation of the monitor shall comply with the safety instructions as listed in chapter [1.3.1 Safety on installation](#)

- Make sure that the installation place has sufficient stability!
- Do not place the monitor near heat sources!
- Use maximum 15mm/0.59 inch long screws. Longer screws may damage the monitor!
- Ensure that the display is operating within the specified operating range +5°C – +40°C | 41°F – 104°F, at max. 90% RH, non-condensing.
- Never restrict airflow into the display by blocking any vents or air intakes.
- Leave a clearance on all vented sides of the display to permit the required airflow. Clearance should be minimum 15 cm but may be larger depending on the ambient environment.



Do not install the unit where it may be easily touched or leaned against. Avoid locations subject to high vibrations or severe impacts. Do not install the unit where it is exposed to humidity, oil, smoke or excessive dust.

2.2.1 Accessories

The product portfolio of accessories comprises a table stand, and wall and ceiling mounts. The installation of the accessories is described in the installation section. The following chapter just gives a rough idea about mounting the table stand.

2.2.2 Mounting of the table stand (optional)

The table stand is an optional component.

The monitors feature on their rear side 2 parallel arrangements of 4 threads each. These threads comply with the VESA standards, their horizontal and vertical distance is 200mm. They are equipped with the respective screws (M8x15).

These screws are used to attach the table stand!

- Lay the monitor upside down on a clean(!) surface, bottom edge flush with e.g. edge of the table.



Soil or particles laying on the surface may irretrievably damage the screen of the monitor!

2. Unpacking and installation

- Take a screwdriver for recessed head screws, size 8.
- Remove the 4 center screws and washers on the rear side of the monitor.

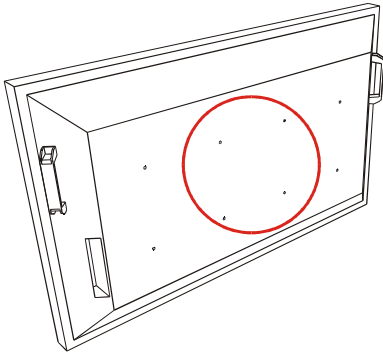

- Take the table stand and attach its mounting plate to the rear of the monitor using the previously removed screws and washers.

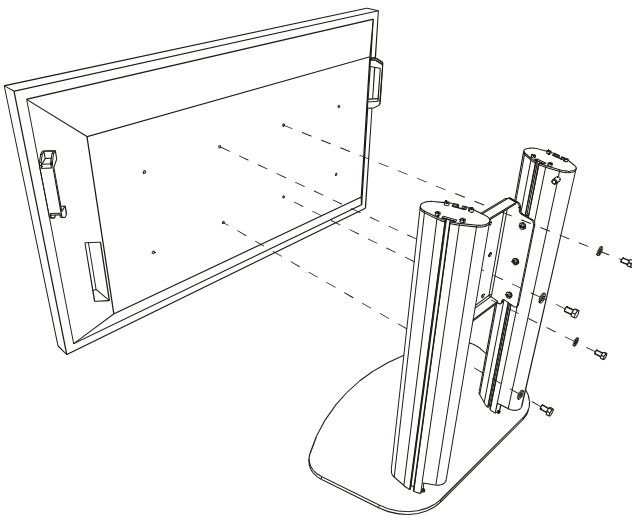

Mind the correct orientation of the table stand!

- When the screws are fastened tightly, put up the monitor

2.2.3 Dimensions of the 42" monitor:

2.2.3.1 Front view

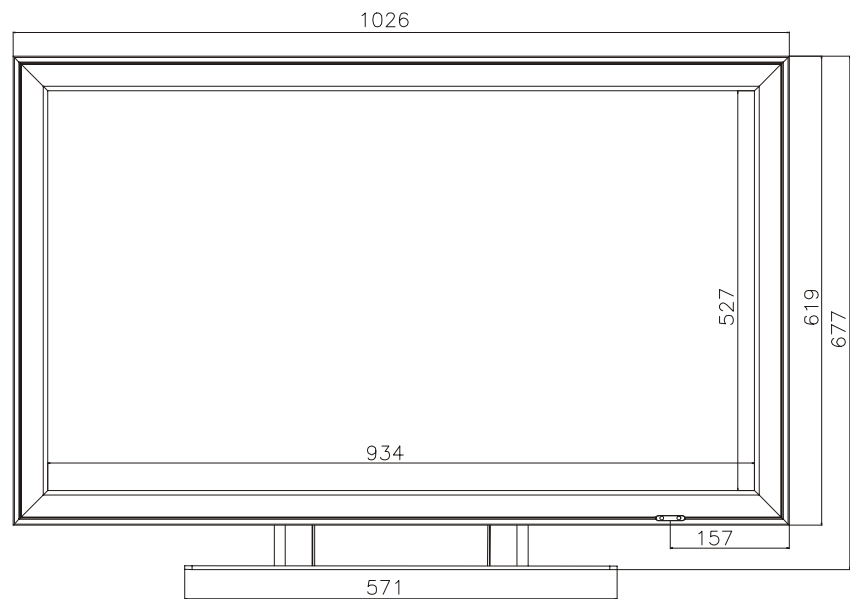

2.2.3.2 Side view and rear view:

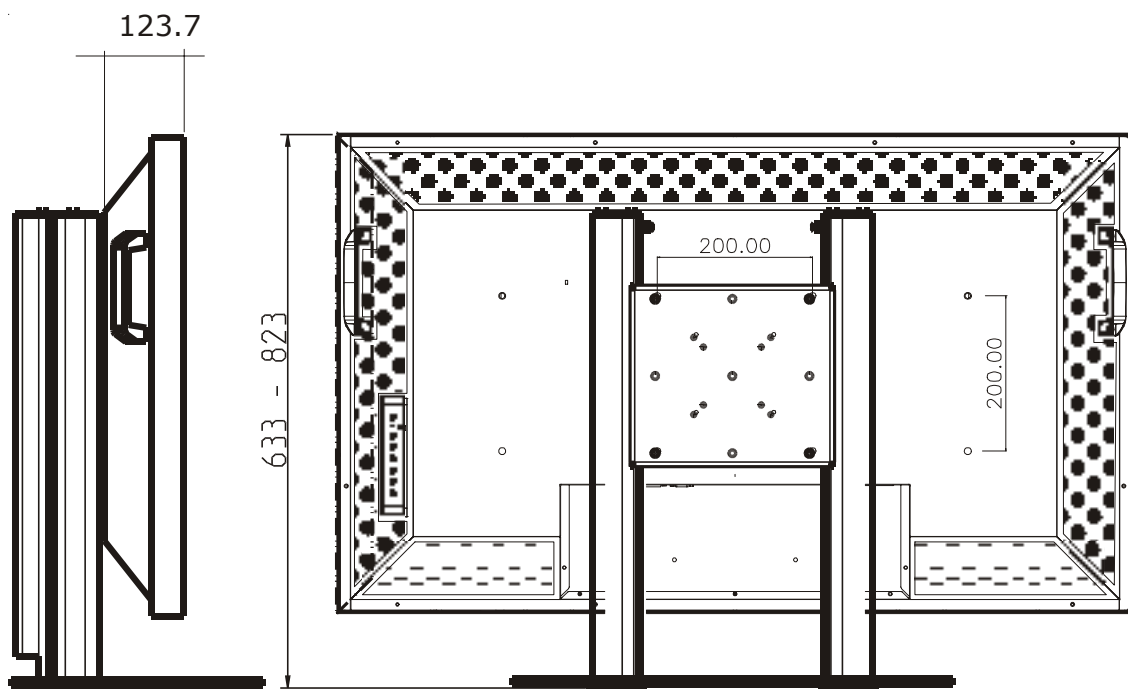

2.2.4 Dimensions of the 47" monitor:

2.2.4.1 Front view

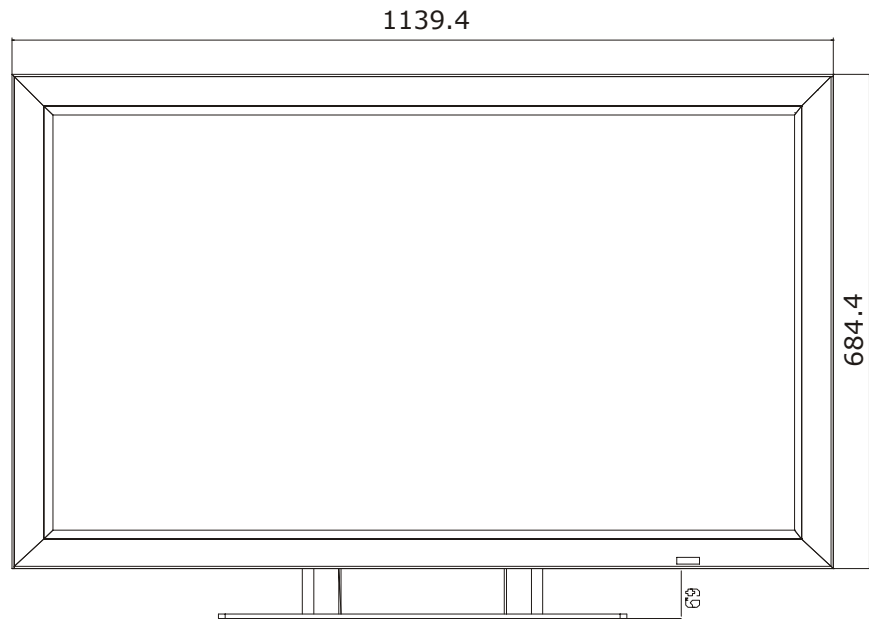

2.2.4.2 Side view and rear view:

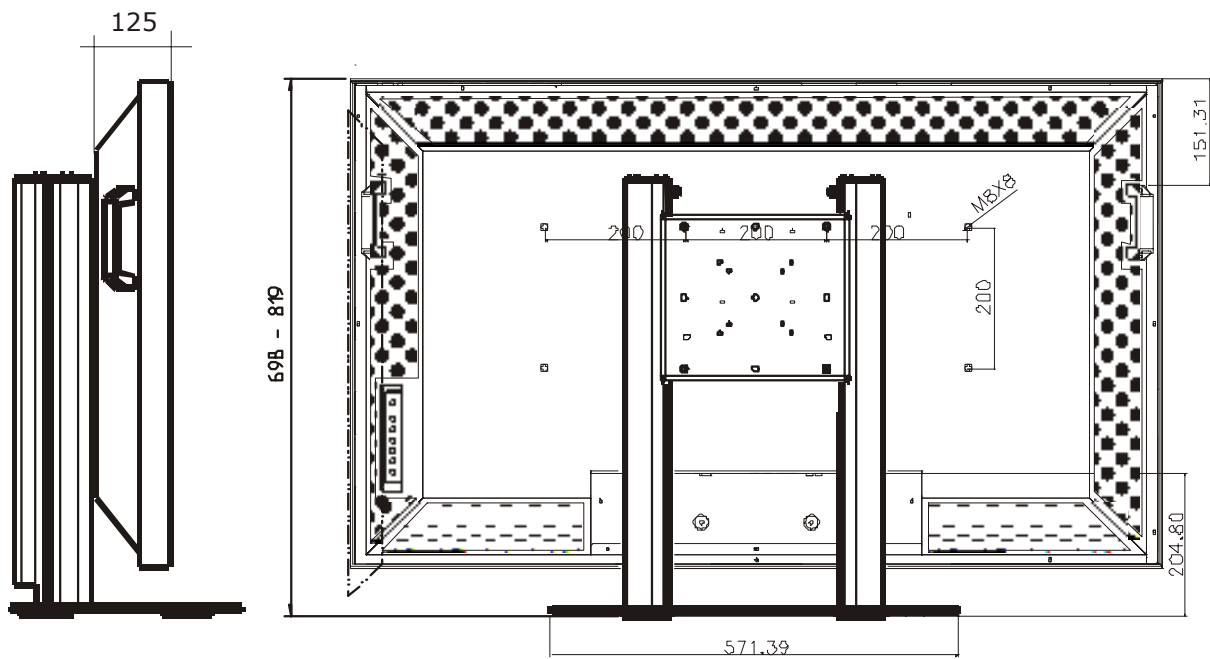

2.3 Examining the monitor

2.3.1 Front view

An LED on the bottom right edge indicates the operating status of the monitor.

LED indicator	Mode
Orange	Standby
Green	In operation

Next to the LED indicator the **sensor** to receive the commands from the IR control unit is located as well as the **light sensor** to determine the surrounding light intensity.



Take care that the sensors are not blocked by any objects placed in front of the monitor!

The preset for dim adjustment and bright adjustment can be set and controlled via the OSD, cf. [5.6.4 L](#).

2.3.2 Side view

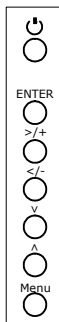

The control elements of monitors are located on the right (seen from front). The 7 push buttons allow switching the monitor from and to standby, to adjust volume and to activate and operate the OSD.

Item	Refers to	Function
1		Standby / switch into operation
2		Activate selection
3		Scroll right for menu items / volume increase
4		Scroll left for menu items / volume decrease
5		Scroll down for menu items / Access signal input menu
6		Scroll up for menu items
7		OSD control menu button / Access or exit main menu / Access or exit submenu / Exit selection

2.3.3 Rear view

On the rear, all interfaces as well as the power connector and the main power switch are located.

The standardized power socket is conform to IEC-320-13 and allows connecting local power cables. The internal power supply is auto ranging from 100VAC to 240VAC.

The monitor allows connecting the following sources:

Input		Interface	signals
Video system input	VIDEO IN	RCA	NTSC/PAL
	S-VIDEO	S-Video Mini Din 4pin	NTSC/PAL
	YUV (Y Pb/Cb Pr/Cr)	Component Mini Din 7 pin	NTSC/PAL
RGB input	RGB Analog	D-Sub 15 pin	RGB analog
	RGB Digital	DVI-D 24 pin	RGB digital
HD-SDI input *)	Serial Digital	BNC	SDI / HD-SDI
HD-SDI output *)	Serial Digital	BNC	SDI / HD-SDI
Signal receive&transmit	RS232 IN	D-Sub 9 pin	
	RS232 OUT	D-Sub 9 pin	
Audio		RCA (red: right (R), white: left (L))	Audio in (L+R) Audio out(L+R) (2x) and Subwoofer

The pin assignments of the interfaces are listed in chapter 7.6 Interfaces and chapter 8.6 Interfaces, respectively.

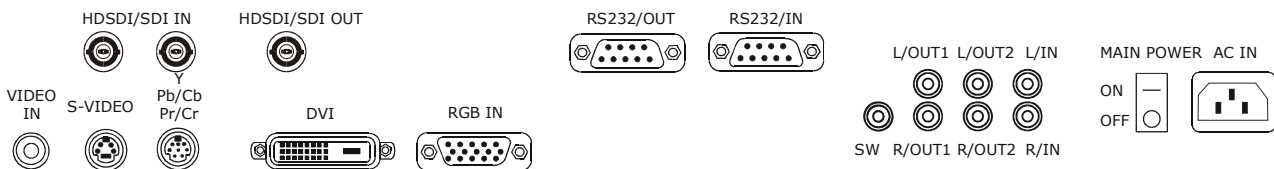

Two sources can be viewed simultaneously in either PIP mode (Picture-in-Picture) or PAP mode (Picture-and-Picture). In case more than one source is connected, the active sources and the display mode (one source or two sources) are selected via the OSD.

*)



Only LCS-42 and LCS-47 feature the HD-SDI interfaces!

2.4 Cabling

All interfaces are located on the rear of the system!



Check the power rating on your outlet before connecting the monitor to the wall outlet or to a power strip. Contact your facilities manager or a qualified electrician if you are not sure what type of power is supplied to your building.



The devices are designed to operate with single-phase power systems having a grounded neutral conductor. To reduce the risk of electrical shock, do not plug into any other type of power system.

- Use the power cord delivered with your system:
- Plug in the female power connector into the male connector AC IN on the rear of the monitor.
- Plug in the CEE7-plug (or ANSI 73.11 plug) into the wall outlet.

The power input is auto-ranging from 100VAC to 240 VAC.

- Connect the video and RGB sources with the respective interface using the included cables.

2.5 Switching on and off

Use the main power switch on the rear of the system to power the system on and off.

When the monitor is powered on, it can be switched into operation or switched to standby, respectively, using either the top most push button on the rear right side of the monitor or using the IR remote control unit (RCU).



If the system is not operated for longer periods, it is recommended to switch it off using the main power switch on the rear side and to disconnect it from the wall outlet.

When the monitor is powered off by switching off the main power switch, the front LED indicating the operating mode is off! Also you cannot switch the unit into operation by using the remote control unit or the top most push button.

To power on the unit, switch on the main power switch on the rear of the system. The LED indicator will be turned on, and you can switch the monitor into operation either by using the RCU or the top most push button the rear of the system.

2.6 Inserting batteries into the Infrared remote control unit

The batteries are not yet inserted in the remote control to avoid remote control operation in its package, resulting in a shorter battery lifetime.

How to install the batteries:

- Push the cover tab with the fingernail a little backwards (as indicated by the arrow) and pull upwards the cover top.
- Slide the cover forwards to remove-
- Insert two AA size batteries, making sure the polarities match the + and - marks inside the battery compartment.
- Insert the lower tab of the battery cover in the gap at the bottom of the remote control, and press the cover until it clicks in place

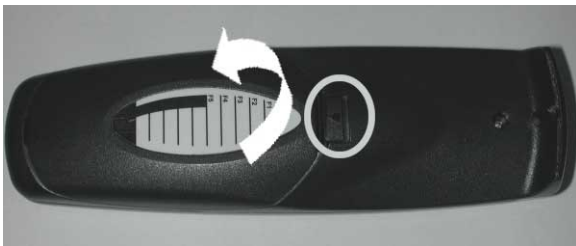

Note that there may be laws concerning disposal and recycling of used batteries in your country! Please contact your local authorities to get further information!



Avoid keeping used, old batteries inside the remote control, causing leakage of internal liquid resulting metal rust or fatal damage to the remote control unit.

3 Design and function

This chapter introduces the systems and explains some of their characteristics.

3.1 Display of choice

The state-of-the-art monitors deliver crisp, clear images detailed to perfection. Compatible with a wide variety of signal sources, they are capable of showing analog video as well as data content.

Sources and interfaces

The monitor provides interfaces to connect composite video, S-Video, component video as well as analog or digital RGB.

Picture-in-Picture

Two of the connected sources can be displayed simultaneously, either next to each other (PAP: picture-and-picture), or one source embedded in the other (PIP: picture in picture).

The sources can be controlled individually (brightness, contrast, color)

Automatic brightness adjustment

A light sensor determines the surrounding light intensity. According the measurement, the panel will adjust to one of the two preset brightness levels: bright mode or dim mode.

User friendliness

The monitors can intuitively be operated and controlled via the OSD and the Infra Red Remote Control Unit (IR RCU).

The language of the OSD can be selected as well as its position on the screen, size, etc.

RS232 remote control is also possible.



In case you want to operate the monitor via RS232 Remote Control, contact Barco about the protocol!

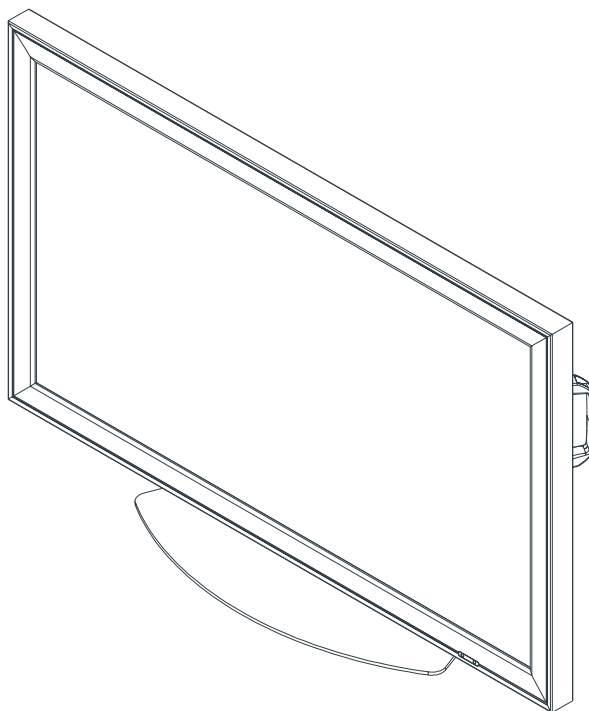

3.2 Technology

The monitors are based on LCD Super MVA technology. The benefits of this technology are wide viewing angles, fast video response and high contrast ratio.

MVA stands for Multidomain Vertical Alignment.

3.2.1 Principle of LCD technology

These are the basics used in LCD technology:

- Light can be polarized
- Liquid crystals can transmit polarized light.
- Liquid crystals align themselves when a voltage is applied.
- Liquid crystals change the light's plane of vibration to match their own angle.

There are multiple operating principles of LCD's; one of them is the Multidomain Vertical Alignment which – not surprising – is based on the Vertical Alignment (VA) technology.

With this operating principle, the LC molecules are completely perpendicular when no voltage is applied, and thus they don't change the polarization of light. Light simply passes the LC, and is blocked by the front end polarizer (since this polarizer is rotated 90° against the back end polarizer which allowed the incident light to pass).

Because the blockage is complete, the quality of black produced this way is excellent!

When voltage is applied, the molecules shift to a horizontal position, producing a white image: the polarization of the light is changed, and light can pass the front end polarizer.

Since the LC molecules are simply switched between vertical and horizontal alignment, response speeds are very fast.

As a further development of the VA technology, with MVA technology the LC cell is divided in sub domains where the molecules are oriented in opposite direction. This widens the viewing angles and enhances the performance.

The following picture shows the basic principle of VA technology:

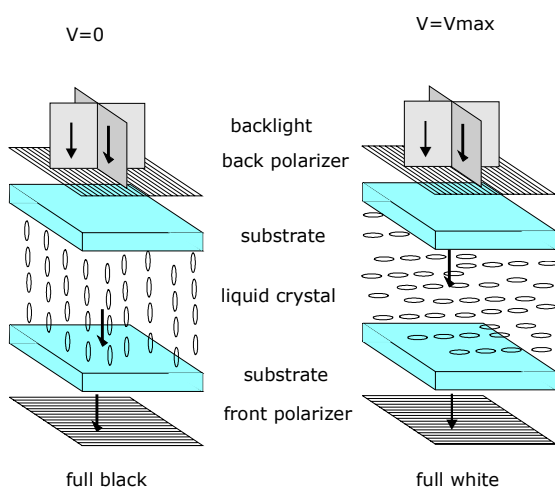

4 Controlling

4.1 General

The monitors can be controlled via the 7 push buttons at the right or conveniently remote-controlled by the infrared remote control unit (**RCU**).



In case you want to use RS232 Remote Control, contact Barco!

The push buttons as well as the IR RCU make use of the OSD: the menu is displayed, a menu item is selected and/or changed. Subsequently the OSD is closed again.

4.1.1 The push buttons

The push buttons are located on the right rear side of the monitor. The seven buttons are arranged in a vertical row and have the following functions:

Push button	Refers to	Function
1 (top most)		Standby / switch into operation
2		Activate selection
3		Scroll right for menu items / volume increase
4		Scroll left for menu items / volume decrease
5		Scroll down for menu items
6		Scroll up for menu items
7		OSD control menu button / Access Main / Sub-menu / Quick Menu Selection

4.1.2 The IR remote control unit

The remote control is used for control, adaptation and source selection. It is also used to switch between standby and operational mode.

The remote control unit (**RCU**) includes a battery powered infrared (IR) transmitter that allows the user to control the monitor remotely.

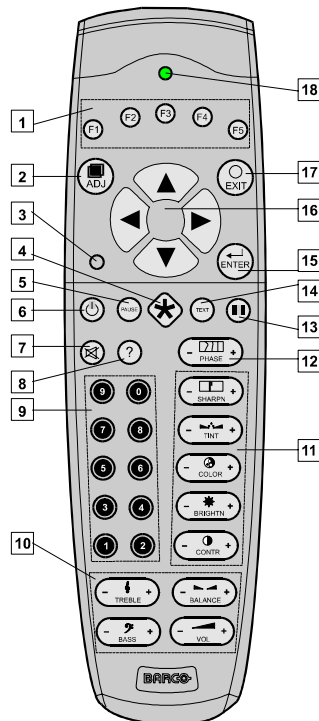

4.2 Terminology of the RCU controls

1	Function keys	
	F1	Source selection
	F2	PIP control setting
	F3	Switch between master source and PIP source
	F4	In VGA mode: White balance
	F5	Shows the RS232 address of the monitor
2	ADJ	ADJUST key, to enter the OSD
3	Address key	has no function for this monitor
4	Selection key	Switch the light sensor on/off
5	PAUSE	Change baud rate of the serial interface
6	Standby	stand by button, to start the monitor when the power switch is switched on and to switch off the monitor without switching off the power switch.
7	Mute	Switch off and on the sound (audio)
8	Help	Indicates the resolution of the input video signal
9	Digit buttons	0-9: have no function for this monitor
10	Audio controls	To control volume, balance, bass and treble of the audio signal
11	Picture controls	Except for brightness and contrast, these keys have no function for this monitor
12	PHASE	Adjust the phase of the signal
13	Freeze	Auto adjust
14	TEXT	Switch on/off the 4:3 mode
15	ENTER	to confirm an adjustment or selection
16	Cursor Keys	to make menu selections in the OSD. RCU cursor key up cursor key down cursor key right cursor key left Use the cursor keys up or right for increasing a value. Use the cursor keys down or left for decreasing a value.
17	EXIT	to leave a menu or the OSD
18	RC operating indication	lights up when a button on the remote control is pressed. (This is a visual indicator to check the operation of the remote control)

How to use the RCU?

Point the front of the **RCU** directly at the screen.



When using the IR remote control, make sure you are within the effective operating distance (30m, 100ft in a straight line). The remote control unit will not function properly if strong light strikes the sensor window or if there are obstacles between the remote control unit and the IR sensor.

4.3 Functions available with the IR Remote Control Unit

4.3.1 Displaying a monitor address

The default (factory) address of a monitor is **1**.

Via the OSD, every monitor can be assigned a unique address in the range of **1** and **255**, cf. [5.6.1 Set display address](#)

With the IR remote control unit, all monitors with any address can be controlled.

With RS232 remote control, the monitors can be controlled individually if they had received a unique display address. (This address can be displayed by means of the function key **F5** on the IR remote control unit).

Press **F5** on the IR remote control unit to display the assigned address of the monitor.

4.3.2 Baud rate setting

The default baud rate for RS232 communication is 115200 baud. The baud rate can be set in the OSD, cf. [5.6.2 Baud rate](#).

With the PAUSE key on the IR RCU the baud rate can directly be set to 115200, 38400, 19200, or 9600, respectively. Press PAUSE to display the currently set baud rate. Press PAUSE again to switch the baud rate to the next lower setting. In case the baud rate is 9600, the next setting will be 115200.

4.3.3 The function keys

Using the function keys, the respective OSD command will immediately be executed.

For information about the commands, please refer to the respective section in the OSD description.

Function key	Description	refers to
F1	Source selection	5.8.1 Input selection with the function key F1,
F2	PIP control setting	5.3.3 PIP control
F3	Switch between master source and PIP source, the source assigned to input 1 will be assigned to input 2 and vice versa	
F4	In VGA mode: White balance	This command has no equivalent in the OSD: when e.g. a signal looks greenish, pressing the function key F4 will correct and adjust the color impression.
F5	Display the monitor address	5.6.1 Set display address

4.3.4 Picture controls with direct access.

Brightness and contrast can be controlled directly via IR RCU. When **Brightness** or **Contrast** is pressed, the respective OSD dialog pops up to allow the adjustment.

Please refer to respective section of the OSD description, cf. [5.3.1.1 Brightness](#), [5.3.1.2 Contrast](#).

4.3.5 Audio controls with direct access.

Volume, balance, bass and treble can be controlled directly via IR RCU. When the respective keys on the IR remote control unit are pressed,, the respective OSD dialog pops up to allow the adjustment.

Please refer to respective section of the OSD description, cf. [5.5 Audio setting menu](#)

5 The On Screen Display (OSD)

5.1 General

The monitors feature an OSD which allows selecting the input, to adjust the sources, to modify OSD settings, etc. When activating the OSD, the main menu is displayed.



Except for the function keys and the direct access keys, it is always the main menu which is the entry level for any modification.

The main menu is activated by pressing **ADJ** on the RCU or by pressing push button **7** (the bottom most push button the right rear side).

A selected menu item shows a blue background, an unselected menu item a gray background.

A selected menu entry looks like a button and it is indicated with a blue dot.

The current status of the menu entry shows a blue background.









If a value has been modified, it will definitely be applied when quitting the dialog (even when pressing EXIT!)

Therefore it is recommended to write down the values: there is no UNDO to a single operation, only the global factory reset.

Grayed out menus or items are not available with the current configuration.

5.1.1 Navigation and adjustment

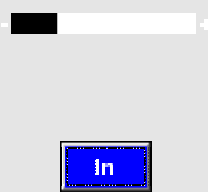
RCU	Icon	Push button (1: top most)
<ul style="list-style-type: none"> Press the ADJ key to activate the OSD 		<ul style="list-style-type: none"> Press 7 to activate the OSD
<ul style="list-style-type: none"> Use the left and right cursor keys to navigate to a menu 		<ul style="list-style-type: none"> Press 3 and 4 to navigate to a menu
<i>Except for signal 1 and signal 2, the menus do not have a submenu.</i>		
<i>Menus without a submenu display their settings dialog as soon as they are activated!</i>		
<ul style="list-style-type: none"> Press Enter to select a menu with a submenu: the menu icon will turn blue 		<ul style="list-style-type: none"> Press 2 to select a menu with a submenu: the menu item will turn blue
<ul style="list-style-type: none"> Use the left and right cursor keys to navigate to a submenu 		<ul style="list-style-type: none"> Press 3 and 4 to navigate to a submenu
<ul style="list-style-type: none"> Press Enter to select: the item will turn blue – or – Press the down cursor key: 		<ul style="list-style-type: none"> Press 2 to select: the item will turn blue – or – Press 5
<ul style="list-style-type: none"> Use the up and down cursor keys to navigate to the entries of a dialog. The entry will get a "button look" and a blue dot. 		<ul style="list-style-type: none"> Press 5 and 6 to navigate to the entries of a dialog. The entry will get a "button look" and a blue dot.
<ul style="list-style-type: none"> In case an option is linked to a button: use the left and right cursor keys to select one of the options 		<ul style="list-style-type: none"> In case an option is linked to a button: use the push buttons 3 / 4 to select one of the options
<ul style="list-style-type: none"> In case increase/decrease is linked to a "slider": use the left and right cursor keys to decrease/increase a value – or – In case increase/decrease is linked to a button: use the Enter key to decrease/increase a value 		<ul style="list-style-type: none"> In case increase/decrease is linked to a "slider": use the push buttons 3 / 4 to decrease increase a value – or – In case increase/decrease is linked to a button: use the push button 2 to increase/decrease a value
As soon as a menu entry loses the focus, i.e. another entry is selected, the respective selection will be applied without any further action: even when quitting the dialog with Exit , the modification will be applied!		
<ul style="list-style-type: none"> Press Exit to deactivate the dialog 		<ul style="list-style-type: none"> Press 7 to deactivate the dialog
<ul style="list-style-type: none"> Press Exit to leave a sub menu Use the left and the right cursor key to navigate to another menu 		<ul style="list-style-type: none"> Press 7 to leave a sub menu Use 3 and 4 to navigate to another menu
<ul style="list-style-type: none"> Press Exit to close the OSD 		<ul style="list-style-type: none"> Press 7 to close the OSD
<i>Closing a first level dialog (i.e. a dialog linked to a menu, not to a sub menu) by means of the Exit key / the push button 7 will close the OSD!</i>		

5.2 Activating the OSD

The OSD can be activated and operated by means of the IR remote control unit (RCU) or the push buttons at the right rear side of the monitor.

RCU	Icon	Push button (1: top most)
<ul style="list-style-type: none"> Press the ADJ key to activate the OSD 	-	<ul style="list-style-type: none"> Press 7 to activate the OSD

Then the main menu is displayed (default: on the upper left corner of the monitor).



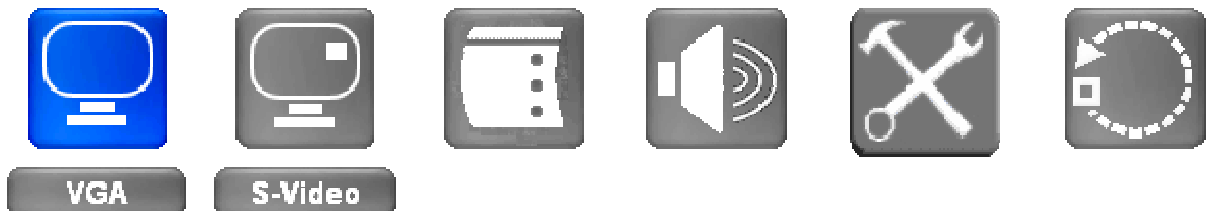

The OSD will be displayed at the position and size as defined in the OSD setting menu. If no modifications have been made via this menu, the OSD will pop up in the upper left corner of the monitor in normal mode (not Zoomed In, background opaque)



Icon	description
	signal menu for the first input, to select and control the settings of a source The currently assigned signal is indicated in the label beneath
	Signal menu for the second input, to select and control the settings of a source The currently assigned signal is indicated in the label beneath
	OSD setting menu, to control the position, transparency and time out of the OSD
	Audio setting menu, to adjust volume, balance, bass and treble
	Parameter setting menu, to set display address, baud rate, light sensor, lower brightness level, ambient light threshold & auto source selection
	Reset menu, to reset to factory defaults. It also shows runtime & serial number of the display

To activate a menu, proceed as follows:

RCU	Icon	Push button (1: top most)
<ul style="list-style-type: none"> Use the left and right cursor key to select a menu 		<ul style="list-style-type: none"> Use the push buttons 3, 4 to select a menu
<ul style="list-style-type: none"> Menus without a submenu will turn blue and display their settings dialog Menus with a sub menu will turn blue and require an additional key stroke to open the settings dialog: Use Enter to open the signal setting sub-menu Use the down cursor key to open the signal selection dialog 		<ul style="list-style-type: none"> Menus without a submenu will turn blue and display their settings dialog Menus with a sub menu will turn blue and require an additional key stroke to open the settings dialog: Use 2 to open the signal setting sub-menu Use 5 to open the signal selection dialog

5.3 The signal menu (first and second input)



The signal menu allows to control and adjust the settings of the source
 The commands can be applied for the first input and for the second input, respectively.
 Please note: the Image setting and Position setting is only available for the first (active) input!



In case more than one source is connected, the signal for input1 and input2 has to be assigned, cf.. 5.8 Input Signal Selection
 The signal for input1 can also be selected via the function key F1, 5.8.1 Input selection with the function key F1

RCU	Icon		Push button (1: top most)
<ul style="list-style-type: none"> Press the ADJ key 	input1	input2	<ul style="list-style-type: none"> Press 7
<ul style="list-style-type: none"> Use the left and right cursor keys to navigate to the signal menu 			<ul style="list-style-type: none"> Press 3 and 4 to navigate to the signal menu
<ul style="list-style-type: none"> Press Enter to select 			<ul style="list-style-type: none"> Press 2 to select
<ul style="list-style-type: none"> Use the left and right cursor keys to navigate to Display 			<ul style="list-style-type: none"> Press 3 and 4 to navigate to Display
<ul style="list-style-type: none"> Press Enter to select 			<ul style="list-style-type: none"> Press 2 to select

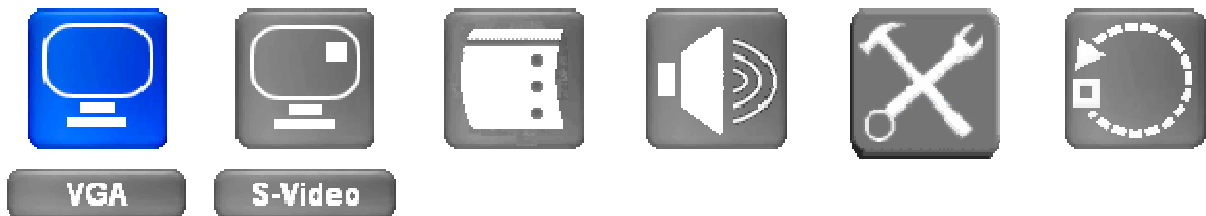

The following sections will use the signal menu of the first input. For the second input, the same dialogs are displayed, however some items are deactivated (Image, Position)
 Nevertheless the dialogs may look different: some commands depend on the type of the source. But this is independent from being input1 or input2!

The source menu button will turn blue. Subsequently the source **sub menu** opens with the items **Display**, **Position**, **PIP Control**, **Image**, and **Color**







Image is only enabled for the source which is assigned to the first input!
The commands of Position are only enabled for the first input!

5.3.1 Display

On the **Display** dialog, brightness and contrast as well as hue, saturation, flesh tone can be adjusted (for VGA sources only: also black level adjustment)

To activate the **Display** dialog, proceed as follows:

RCU	Icon	Push button (1: top most)
<ul style="list-style-type: none"> Press the ADJ key to activate the OSD 		<ul style="list-style-type: none"> Press 7 to activate the OSD
<ul style="list-style-type: none"> Use the left and right cursor keys to navigate to the signal menu 		<ul style="list-style-type: none"> Press 3 and 4 to navigate to the signal menu
<ul style="list-style-type: none"> Press Enter to select 		<ul style="list-style-type: none"> Press 2 to select
<ul style="list-style-type: none"> Use the left and right cursor keys to navigate to Display 		<ul style="list-style-type: none"> Press 3 and 4 to navigate to Display
<ul style="list-style-type: none"> Press Enter to select – or – Press the down key to activate the dialog 		<ul style="list-style-type: none"> Press 2 to select – or – Press 5 to activate the dialog

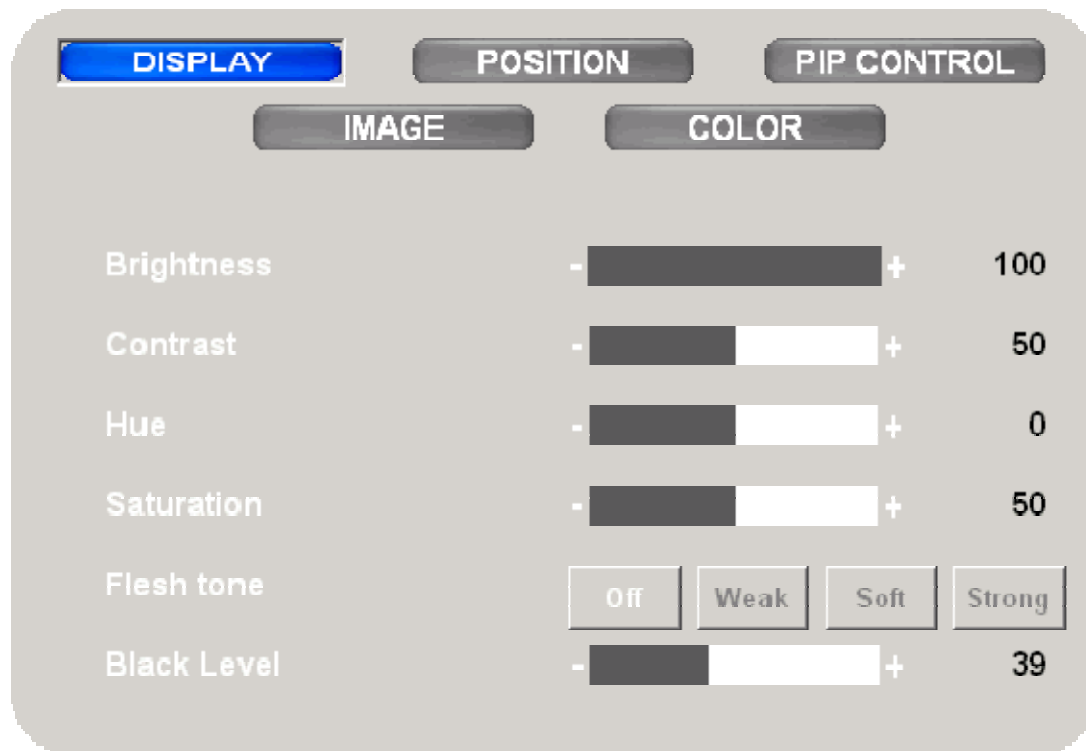
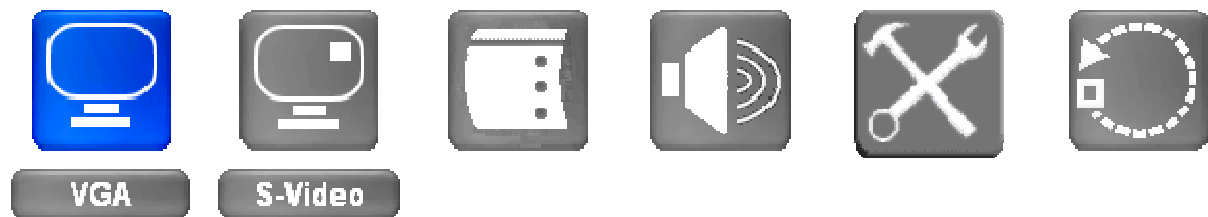

5.3.1.1 Brightness

Brightness can be adjusted in the range between 0 and 100.

*LCD panel screens are lit with built-in fluorescent tubes above, beside and sometimes behind the LCD (Cold Cathode Fluorescent Lamp, CCFL). This light is adjusted using the **Brightness** setting.*

How brightness is perceived depends on the environment and on the content being viewed, which means that switching a source and/or the ambient light could require re-adjustment of brightness.



How bright a pixel is perceived depends on both, brightness setting and contrast setting: brightness setting affects all levels from white to black at once. Contrast setting affects all but black.

RCU	Push button (1: top most)
<ul style="list-style-type: none"> Use the up and down cursor keys to navigate to the Brightness 	<ul style="list-style-type: none"> Press 5 and 6 to navigate to Brightness
<ul style="list-style-type: none"> Use the left and right cursor keys to increase/decrease the value in steps of 1 The current value is indicated. 	<ul style="list-style-type: none"> Use 3 and 4 to increase/decrease the value in steps of 1 The current value is indicated.
The value is applied without any further action.	

5.3.1.2 Contrast

Contrast can be adjusted in the range between 0 and 100.

The information content of a picture is related to contrast, not to brightness. The ratio between the brightest white and the darkest black that a display can produce in a completely dark room is called the full field contrast ratio.

RCU	Push button (1: top most)
<ul style="list-style-type: none"> Use the up and down cursor keys to navigate to the Contrast 	<ul style="list-style-type: none"> Press 5 and 6 to navigate to Contrast
<ul style="list-style-type: none"> Use the left and right cursor keys to increase/decrease the value in steps of 1 The current value is indicated. 	<ul style="list-style-type: none"> Use 3 and 4 to increase/decrease the value in steps of 1 The current value is indicated.
The value is applied without any further action.	

5.3.1.3 Hue

Hue can be adjusted in the range between -45 and +45.

The color = hue is most noticeable in areas of white.

There are multiple color models, one of them is the HSV model describing color as hue (color), saturation (the amount of white light in the color), and V (value, the amount of black/lightness/brightness).



With PAL, part of the color information on the video signal is reversed in phase with each line, which automatically corrects phase errors in the transmission of the signal.

*With NTSC, the **Hue** control allows to perform the correction manually and to adjust the color*

RCU	Push button (1: top most)
<ul style="list-style-type: none"> Use the up and down cursor keys to navigate to the Hue 	<ul style="list-style-type: none"> Press 5 and 6 to navigate to Hue
<ul style="list-style-type: none"> Use the left and right cursor keys to increase/decrease the value in steps of 1 The current value is indicated. 	<ul style="list-style-type: none"> Use 3 and 4 to increase/decrease the value in steps of 1 The current value is indicated.
The value is applied without any further action.	

5.3.1.4 Saturation

Saturation can be adjusted in the range between 0 and 100.

Saturation adjusts the amount of white light in the color.

RCU	Push button (1: top most)
<ul style="list-style-type: none"> Use the up and down cursor keys to navigate to the Saturation 	<ul style="list-style-type: none"> Press 5 and 6 to navigate to Saturation
<ul style="list-style-type: none"> Use the left and right cursor keys to increase/decrease the value in steps of 1 The current value is indicated. 	<ul style="list-style-type: none"> Use 3 and 4 to increase/decrease the value in steps of 1 The current value is indicated.
The value is applied without any further action.	

5.3.1.5 Flesh tone

Flesh tone can be switched **off**, or turned on **weak**, **soft**, or **strong**.

When in bright areas of the pictures the skin-tones show chalky white, the normal skin tone color can be restored.

RCU	Push button (1: top most)
<ul style="list-style-type: none"> Use the up and down cursor keys to navigate to the Flesh tone 	<ul style="list-style-type: none"> Press 5 and 6 to navigate to Flesh tone
<ul style="list-style-type: none"> Use the left and right cursor keys to select one of the options Off, Weak, Soft, Strong The current selection is visualized by a white caption. 	<ul style="list-style-type: none"> Use 3 and 4 to select one of the options Off, Weak, Soft, Strong The selection value is visualized by a white caption.
The selection is applied without any further action.	

5.3.1.6 Black level (only available for analog RGB)

Black level can be adjusted in the range between 0 and 100.

The black level is the deepest black of the monitor.

RCU	Push button (1: top most)
<ul style="list-style-type: none">Use the up and down cursor keys to navigate to the Black Level	<ul style="list-style-type: none">Press 5 and 6 to navigate to Black Level
<ul style="list-style-type: none">Use the left and right cursor keys to increase/decrease the value in steps of 1 The current value is indicated.	<ul style="list-style-type: none">Use 3 and 4 to increase/decrease the value in steps of 1 The current value is indicated.
The value is applied without any further action.	

5.3.2 Position

On the **Position** dialog, the vertical and horizontal position of the image can be set as well as an area for zooming defined.

RCU	Icon	Push button (1: top most)
<ul style="list-style-type: none"> Press the ADJ key to activate the OSD 		<ul style="list-style-type: none"> Press 7 to activate the OSD
<ul style="list-style-type: none"> Use the left and right cursor keys to navigate to the signal menu 		<ul style="list-style-type: none"> Press 3 and 4 to navigate to the signal menu
<ul style="list-style-type: none"> Press Enter to select 		<ul style="list-style-type: none"> Press 2 to select
<ul style="list-style-type: none"> Use the left and right cursor keys to navigate to Position 		<ul style="list-style-type: none"> Press 3 and 4 to navigate to Position
<ul style="list-style-type: none"> Press Enter to select – or – Press the down key to activate the dialog 		<ul style="list-style-type: none"> Press 2 to select – or – Press 5 to activate the dialog

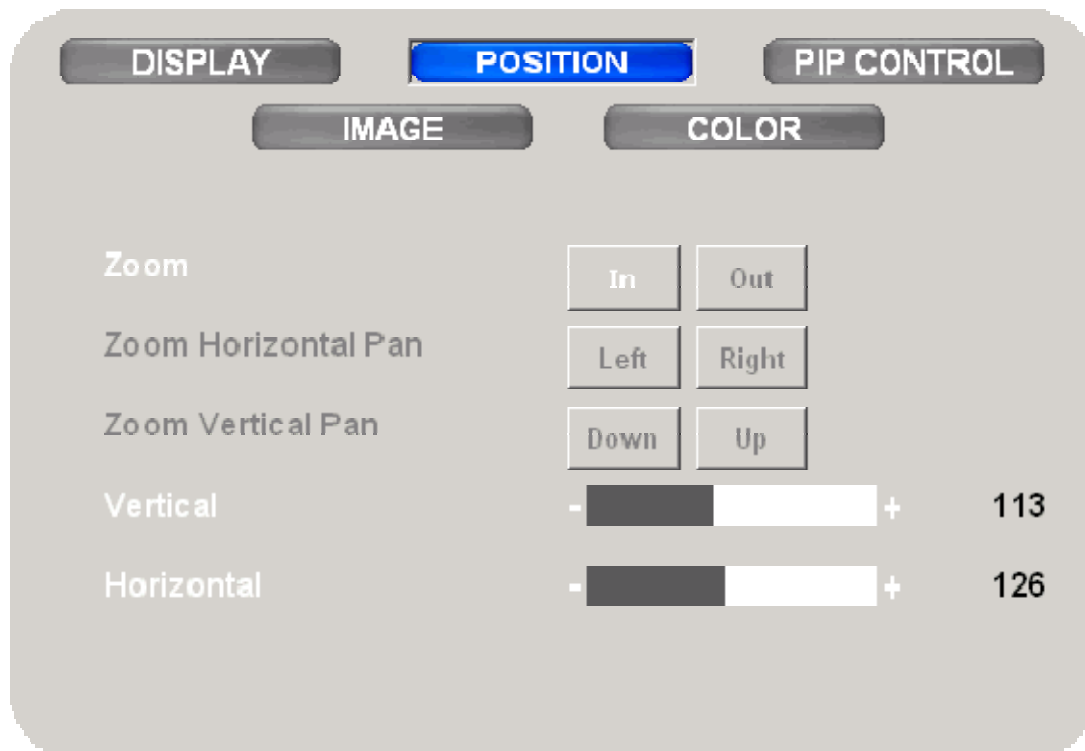
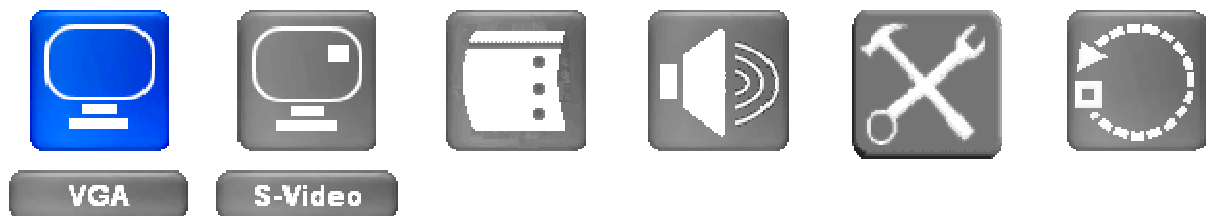

The entries of Position are only enabled for the signal assigned to input 1.

5.3.2.1 Zoom

Zoom can be selected to **In** and **Out**.

Zoom In means to magnify the displayed picture. The magnification factor is related to the number of times the **In** button is activated. (The reverse operation is **Zoom Out** which reduces the picture back to the previous size).

The center of the original picture content will be "fixed" in the center of the monitor.

Due to the magnification, no longer the entire frame of the picture is displayed. To select the part of the frame to be viewed, use the commands **Zoom Horizontal Pan** and **Zoom Vertical Pan**. Activating the **Left/Right** button and the **Down/Up** button respectively resembles using the horizontal and vertical scrollbar to move the desired portion of the picture content into the active window.

Each activation of the button means moving the picture 5 pixels in the selected direction.

RCU	Push button (1: top most)
<ul style="list-style-type: none"> Use the up and down cursor keys to navigate to the Zoom 	<ul style="list-style-type: none"> Press 5 and 6 to navigate to Zoom
<ul style="list-style-type: none"> Use the left and right cursor keys to select one of the options In, Out. The current value is visualized by a white caption. 	<ul style="list-style-type: none"> Use 3 and 4 to select one of the options In, Out. The current value is visualized by a white caption.
<ul style="list-style-type: none"> Use the Enter to increase/decrease the zoom factor. 	<ul style="list-style-type: none"> Use 2 to increase/decrease the zoom factor



Zoom Horizontal Pan and Zoom Vertical Pan is only available if the picture has been Zoomed In, i.e. has been magnified and the display can no longer show the entire content of the picture frame.

5.3.2.2 Zoom Horizontal Pan

Zoom Horizontal Pan can be selected to **Left** and **Right**

RCU	Push button (1: top most)
<ul style="list-style-type: none"> Use the up and down cursor keys to navigate to the Zoom Horizontal Pan 	<ul style="list-style-type: none"> Press 5 and 6 to navigate to Zoom Horizontal Pan
<ul style="list-style-type: none"> Use the left and right cursor keys to select one of the options Left, Right. The current selection is visualized by a white caption. 	<ul style="list-style-type: none"> Use 3 and 4 to select one of the options Left, Right. The current selection is visualized by a white caption.
<ul style="list-style-type: none"> Use the Enter to move the picture content in the desired direction. 	<ul style="list-style-type: none"> Use 2 to move the picture content in the desired direction.

5.3.2.3 Zoom Vertical Pan

Zoom Vertical Pan can be set to **Up** and **Down**

RCU	Push button (1: top most)
<ul style="list-style-type: none"> Use the up and down cursor keys to navigate to the Zoom Vertical Pan 	<ul style="list-style-type: none"> Press 5 and 6 to navigate to Zoom Vertical Pan
<ul style="list-style-type: none"> Use the left and right cursor keys to select one of the options Up, Down. The current selection is visualized by a white caption. 	<ul style="list-style-type: none"> Use 3 and 4 to select one of the options Up, Down The current selection is visualized by a white caption.
<ul style="list-style-type: none"> Use the Enter to move the picture content in the desired direction. 	<ul style="list-style-type: none"> Use 2 to move the picture content in the desired direction.

5.3.2.4 Vertical

Vertical can be adjusted in the range from 0 and 255.



Vertical and Horizontal moves the screen content within the allocated position ("centered window") of the monitor. It is not possible to move e.g. a PAL Video (720x540) with display mode 1:1 to the upper left corner of the monitor: the allocated position is in the range 600pixel to 1320pixel (horizontal, counting started on the top left corner) and in the range 270pixel to 810pixel (vertical, counting started on the top left corner).

RCU	Push button (1: top most)
<ul style="list-style-type: none"> Use the up and down cursor keys to navigate to the Vertical. 	<ul style="list-style-type: none"> Press 5 and 6 to navigate to Vertical.
<ul style="list-style-type: none"> Use the left and right cursor keys to move the picture content in steps of 1 The current value is indicated. 	<ul style="list-style-type: none"> Use 3 and 4 to move the picture content in steps of 1 The current value is indicated.
The value is applied without any further action, e.g. the picture content is shifted in the desired direction.	

5.3.2.5 Horizontal

Horizontal can be adjusted in the range from 0 and 255.

RCU	Push button (1: top most)
<ul style="list-style-type: none"> Use the up and down cursor keys to navigate to the Horizontal. 	<ul style="list-style-type: none"> Press 5 and 6 to navigate to Horizontal.
<ul style="list-style-type: none"> Use the left and right cursor keys to move the picture content in steps of 1 The current value is indicated. 	<ul style="list-style-type: none"> Use 3 and 4 to move the picture content in steps of 1 The current value is indicated.
The value is applied without any further action, e.g. the picture content is shifted in the desired direction.	

5.3.3 PIP control

On the **PIP CONTROL** dialog, the vertical and horizontal position of the image can be set as well as an area for the embedded picture be defined.

PIP means picture-in-picture and displays dual moving images from two separate sources (e.g., PC and video) at the same time.

There are two different ways: one source is displayed in full size, and the other one is displayed in a small size overlaying the full screen picture. The full screen picture is called master source, and the other one PIP source.

Besides this display mode, the two sources can be displayed "side to side", which is called PAP mode (picture and picture).

The source selected on input 1 is always the master source, the source selected on input 2 is always the PIP source.

The master source and the PIP source can be switched by means of the function key **F3** on the **RCU** (which in fact is changing sources at the inputs).



PIP settings made with input 2 are only applied when input 2 becomes the PIP master!

To activate the **PIP CONTROL** dialog, proceed as follows:

RCU	Icon	Push button (1: top most)
<ul style="list-style-type: none"> Press the ADJ key to activate the OSD 		<ul style="list-style-type: none"> Press 7 to activate the OSD
<ul style="list-style-type: none"> Use the left and right cursor keys to navigate to the signal menu 		<ul style="list-style-type: none"> Press 3 and 4 to navigate to the signal menu
<ul style="list-style-type: none"> Press Enter to select 		<ul style="list-style-type: none"> Press 2 to select
<ul style="list-style-type: none"> Use the left and right cursor keys to navigate to PIP control 		<ul style="list-style-type: none"> Press 3 and 4 to navigate to PIP Control
<ul style="list-style-type: none"> Press Enter to select – or – Press the down key to activate the dialog 		<ul style="list-style-type: none"> Press 2 to select – or – Press 5 to activate the dialog

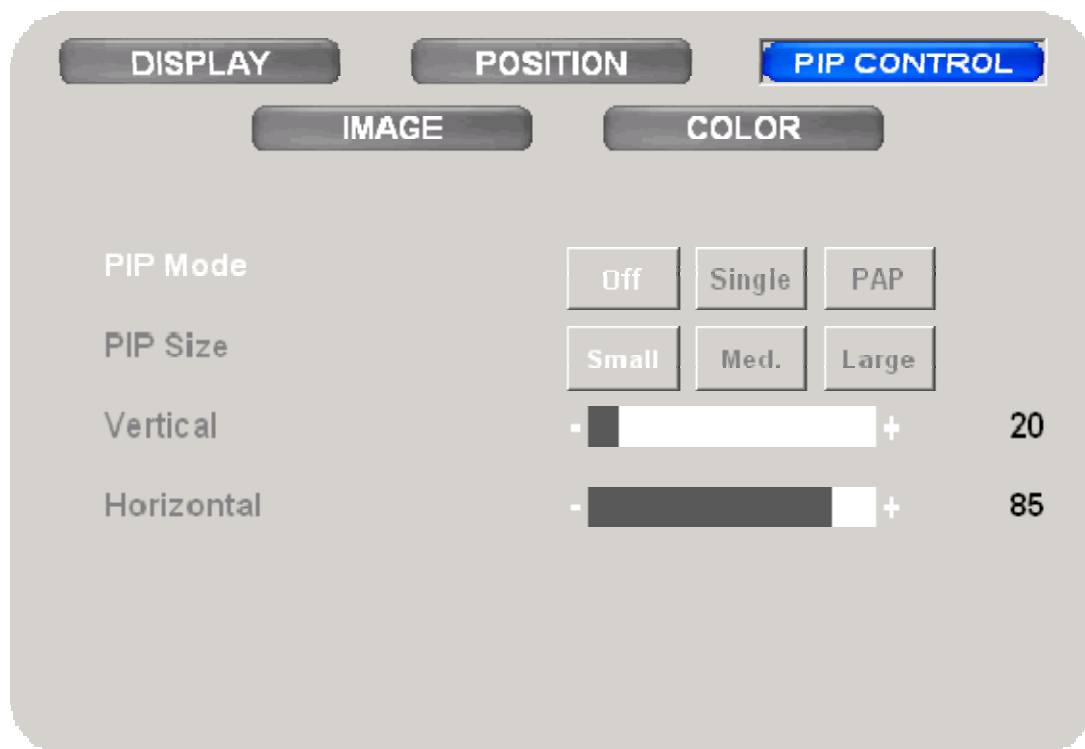
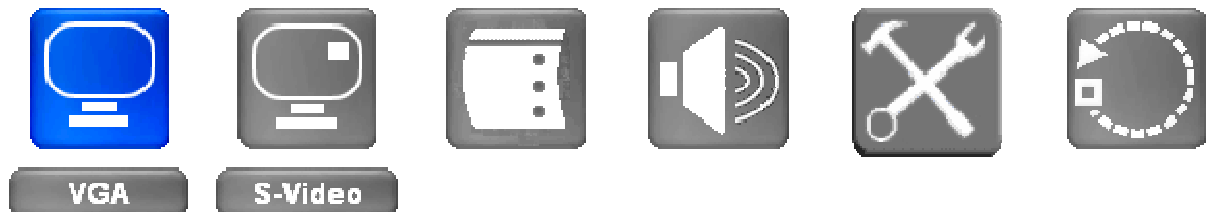

5.3.3.1 PIP Mode

PIP Mode can be set to off, single, PAP.

*When PIP mode is **Off**, only one source is displayed.*

*When PIP mode is **Single**, the source connected to input 1 is the master source and displayed according its settings, whereas the source connected to input 2 is the PIP source and displayed either in **Small, Medium or Large** size according the **PIP Size** selections.*

*The position of the PIP source is set using the **Vertical** and **Horizontal** adjustment.*



PIP Size, Vertical and Horizontal are only enabled if PIP Mode is selected Single.



In case no source is connected to input 2, Single will result in an empty window with blue borders, PAP will result in displaying source1 at the left half of the monitor (right half remains black).

RCU	Push button (1: top most)
<ul style="list-style-type: none"> Use the up and down cursor keys to navigate to the PIP Mode 	<ul style="list-style-type: none"> Press 5 and 6 to navigate to PIP Mode
<ul style="list-style-type: none"> Use the left and right cursor keys to select one of the options Off, Single, PAP The current selection is visualized by a white caption. 	<ul style="list-style-type: none"> Use 3 and 4 to select one of the options Off, Single, PAP The current selection is visualized by a white caption.
The selection is applied without any further action.	



Using the direct access key F2, the selected PIP mode can be toggled between On and Off. Using the direct access key F3, the PIP master and the PIP source can be toggled.

5.3.3.2 PIP Size

PIP size can be set to small, medium, and large.

RCU	Push button (1: top most)
<ul style="list-style-type: none"> Use the up and down cursor keys to navigate to the PIP Size 	<ul style="list-style-type: none"> Press 5 and 6 to navigate to PIP Size
<ul style="list-style-type: none"> Use the left and right cursor keys to select one of the options Small, Medium, Large. The current selection is visualized by a white caption. 	<ul style="list-style-type: none"> Use 3 and 4 to select one of the options Small, Medium, Large. The current selection is visualized by a white caption.
The selection is applied without any further action.	

5.3.3.3 Vertical

Vertical can be adjusted in the range from 0 to 255.

RCU	Push button (1: top most)
<ul style="list-style-type: none"> Use the up and down cursor keys to navigate to the Vertical 	<ul style="list-style-type: none"> Press 5 and 6 to navigate to Vertical
<ul style="list-style-type: none"> Use the left and right cursor keys to increase/decrease the value in steps of 1. The current value is indicated. (increase: move down/decrease: move up) 	<ul style="list-style-type: none"> Use 3 and 4 to increase/decrease the value in steps of 1. The current value is indicated. (increase: move down/decrease: move up)
The value is applied without any further action.	

5.3.3.4 Horizontal

Horizontal can be adjusted in the range from 0 to 255.

RCU	Push button (1: top most)
<ul style="list-style-type: none"> Use the up and down cursor keys to navigate to the Horizontal 	<ul style="list-style-type: none"> Press 5 and 6 to navigate to Horizontal
<ul style="list-style-type: none"> Use the left and right cursor keys to increase/decrease the value in steps of 1. The current value is indicated. (increase: move right/decrease: move left) 	<ul style="list-style-type: none"> Use 3 and 4 to increase/decrease the value in steps of 1. The current value is indicated. (increase: move right/decrease: move left)
The value is applied without any further action.	

5.3.4 Combination of signals for main image and PiP/PaP

The following table lists the combination of signals for input 1 (main input) and input 2 (PiP/PaP). Not all combinations are possible; some cause disturbances or result in images which are not properly scaled.

Input 1	Input 2	Comment
VGA	DVI	only possible for low resolutions, higher resolutions cause an error message (Pixel rate > 110MHz), not recommended with Barco Transform H system.
	HD-SDI 1 or HD-SDI 2	OK
	S-Video or Composite or Component	OK
DVI	VGA	only possible for low resolutions, higher resolutions cause an error message (Pixel rate > 110MHz), not recommended with Barco Transform H system.
	HD-SDI 1 or HD-SDI 2	OK
	S-Video or Composite or Component	OK

Input 1	Input 2	Comment
HD-SDI 1 or HD-SDI 2	VGA or DVI	OK
	S-Video or Composite or Component	Not possible
S-Video or Composite or Component	VGA or DVI	OK
	HD-SDI 1 or HD-SDI 2	Not possible

5.3.5 Image

On the **Image** dialog, the settings of the signal can be optimized.



For best image results, use short cables between the source and the monitor!

The image dialog depends on the source:

In case of analog RGB, the image settings comprises Scaling, Auto adjust, Phase, and Clock.

In case of S-Video/Video, the image settings comprise Scaling, Noise Reduction, Angle Filter, Film Mode Detect, Sharpness.





In case of a DVI, due to the digital interface, no adjustment is required. Therefore the dialog only comprises Scaling-



Image is only enabled for the source assigned to input 1!

To do the image adjustment for the source of input 2, this source has to be assigned to input 1.

To activate the **Image** dialog, proceed as follows:

RCU	Icon	Push button (1: top most)
<ul style="list-style-type: none"> Press the ADJ key to activate the OSD 		<ul style="list-style-type: none"> Press 7 to activate the OSD
<ul style="list-style-type: none"> Use the left and right cursor keys to navigate to the signal menu 		<ul style="list-style-type: none"> Press 3 and 4 to navigate to the signal menu
<ul style="list-style-type: none"> Press Enter to select 		<ul style="list-style-type: none"> Press 2 to select
<ul style="list-style-type: none"> Use the left and right cursor keys to navigate to Image 		<ul style="list-style-type: none"> Press 3 and 4 to navigate to Image
<ul style="list-style-type: none"> Press Enter to select – or – Press the down key to activate the dialog 		<ul style="list-style-type: none"> Press 2 to select – or – Press 5 to activate the dialog

5.3.5.1 Analog RGB

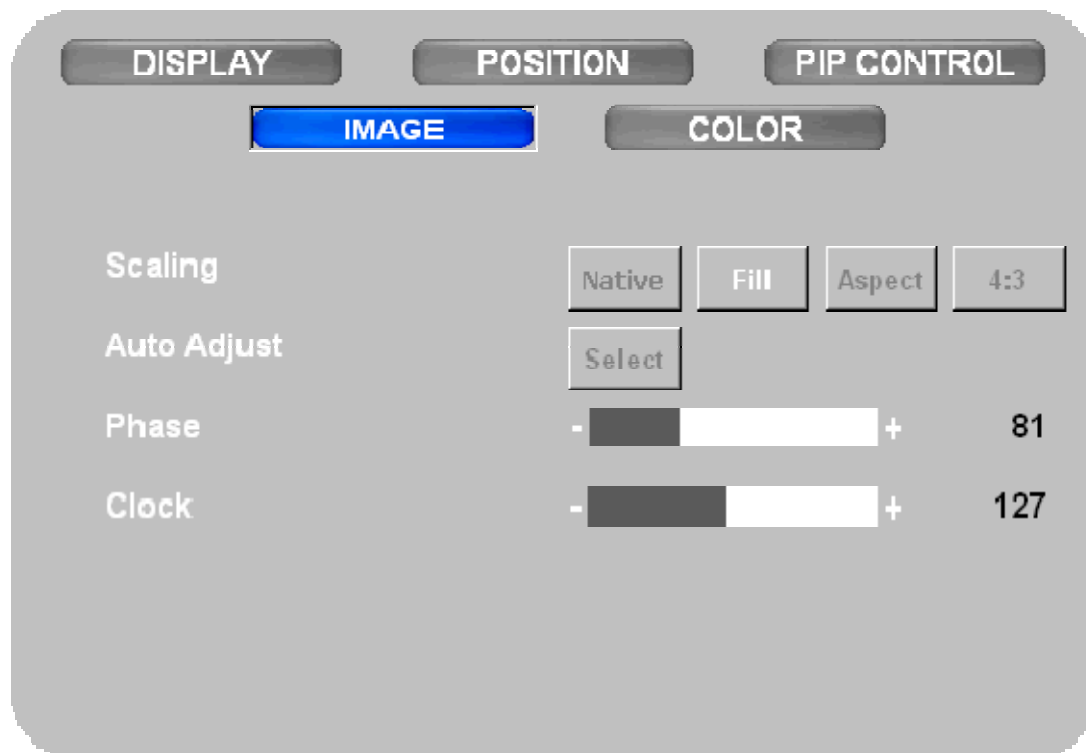
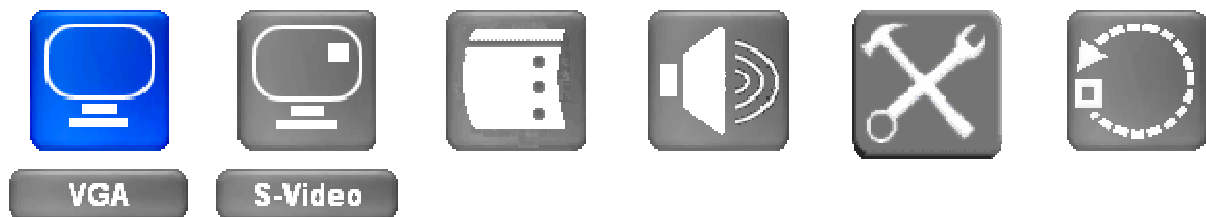

Scaling

Scaling can be set to Native, Fill, Aspect, and 4:3.

Scaling means changing the resolution of an image.

Native is only enabled when the detected resolution of the source is lower than the resolution of the monitor.

The monitor has a resolution of 1920x1080 pixel. In case the resolution of the source is lower (e.g. a PAL Video with 720x540 pixels), when displayed 1:1, there will be a black border around the content.

*In case **Fill** is selected, the content is displayed on the entire screen which, in case the ratio of the source is different from the ratio of the screen (e.g. a PAL Video, 4:3), results in a distortion of the content: with PAL, in horizontal direction, the pixels would be multiplied by a factor of 2.6, whereas in vertical direction the factor would be 2.0.*

*With **Aspect**, the aspect ratio of the source is maintained: in the above mentioned example, the pixels both in horizontal and in vertical direction would be multiplied by a factor of two, thus the content would have a black border of 240 pixels both, on the left side and on the right side.*

4:3: *if a PAL/NTSC source is connected to an input, the 4:3 setting displays the source without any distortion (e.g. a circle remains a circle).*

RCU	Push button (1: top most)
<ul style="list-style-type: none"> Use the up and down cursor keys to navigate to the Scaling 	<ul style="list-style-type: none"> Press 5 and 6 to navigate to Scaling
<ul style="list-style-type: none"> Use the left and right cursor keys to select one of the options Native, Fill, Aspect, 4:3. The current selection is visualized by a white caption. 	<ul style="list-style-type: none"> Use 3 and 4 to select one of the options Native, Fill, Aspect, 4:3. The current selection is visualized by a white caption.
The selection is applied without any further action.	

Auto Adjust

When **Auto Adjust** is selected, the monitor adjusts itself to the timing of the source which matches best one of the internal preset timings.



Use the key FREEZE on the remote control unit to immediately start Auto Adjust.

During the Auto Adjust process, the monitor displays an information "Auto Configuration".

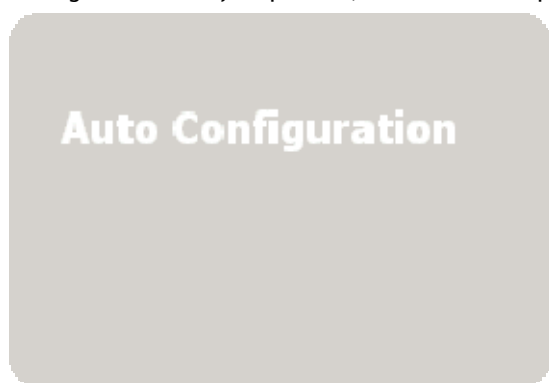

In case Auto Adjust is not selected, or the results are not perfect, the timing of the source has to be manually adjusted to the timing of the monitor using the controls Phase and Clock.

Both controls are to minimize the interferences (noise). Clock is course adjustment whereas Phase is fine tuning of the setting.

To do the adjustment, use a test pattern (e.g. vertical stripes) of the connected source!

RCU	Push button (1: top most)
<ul style="list-style-type: none"> Use the up and down cursor keys to navigate to the Auto Adjust 	<ul style="list-style-type: none"> Press 5 and 6 to navigate to Auto Adjust
<ul style="list-style-type: none"> Use the left and right cursor keys to select Select. The current selection is visualized by a white caption. 	<ul style="list-style-type: none"> Use 3 and 4 to select Select <p>The current selection is visualized by a white caption.</p>
The selection is applied without any further action.	

Phase

Phase can be adjusted in the range from 0 to 255.

It is recommended to have the monitor warmed up for about 5 minutes before adjusting phase.

*Use the **Phase** adjustment to eliminate shimmering horizontal streaking.*



If there are not only horizontal streaking but also vertical banding, start with Clock adjustment!

RCU	Push button (1: top most)
<ul style="list-style-type: none"> Use the up and down cursor keys to navigate to the Phase 	<ul style="list-style-type: none"> Press 5 and 6 to navigate to Phase
<ul style="list-style-type: none"> Use the left and right cursor keys to increase/decrease the value in steps of 1 The current value is indicated. 	<ul style="list-style-type: none"> Use 3 and 4 to increase/decrease the value in steps of 1 The current value is indicated.
The value is applied without any further action. Check the test pattern!	

Clock

Clock can be adjusted in the range from 0 to 255.

It is recommended to have the monitor warmed up for about 5 minutes before adjusting clock.

*Use the **Clock** adjustment to eliminate broad vertical banding.*

RCU	Push button (1: top most)
<ul style="list-style-type: none"> Use the up and down cursor keys to navigate to the Clock 	<ul style="list-style-type: none"> Press 5 and 6 to navigate to Clock
<ul style="list-style-type: none"> Use the left and right cursor keys to increase/decrease the value in steps of 1 The current value is indicated. 	<ul style="list-style-type: none"> Use 3 and 4 to increase/decrease the value in steps of 1 The current value is indicated.
The value is applied without any further action. Check the test pattern!	

5.3.5.2 S-Video

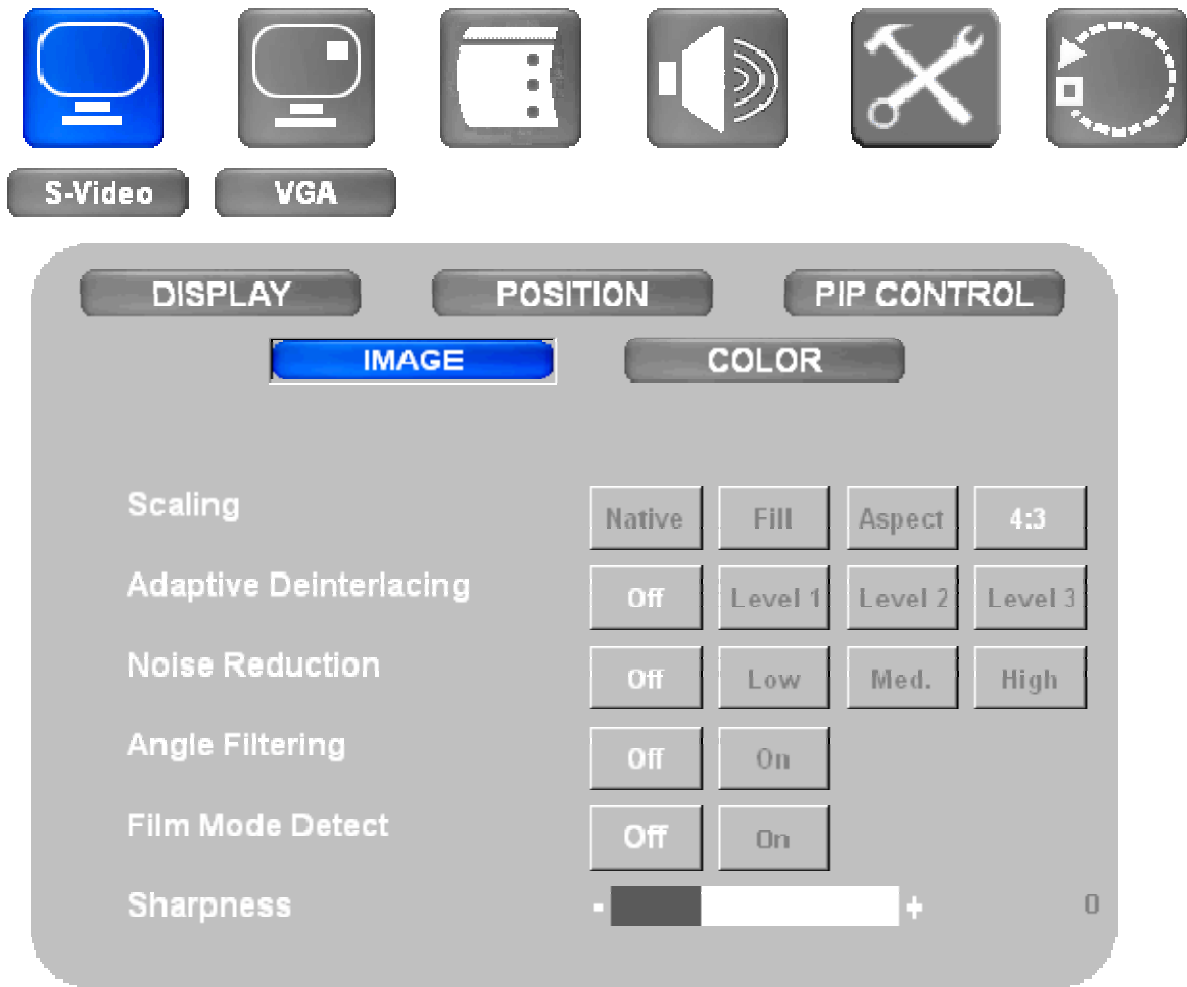

Scaling

Scaling can be set to Native, Fill, Aspect, and 4:3..

Scaling means changing the resolution of an image.

Native is only enabled when the detected resolution of the source is lower than the resolution of the monitor.

The monitor has a resolution of 1920x1080 pixel. In case the resolution of the source is lower (e.g. a PAL Video with 720x540 pixels), when displayed 1:1, there will be a black border around the content.

*In case **Fill** is selected, the content is displayed on the entire screen which, in case the ratio of the source is different from the ratio of the screen (e.g. a PAL Video, 4:3), results in a distortion of the content: with PAL, in horizontal direction, the pixels would be multiplied by a factor of 2.6, whereas in vertical direction the factor would be 2.0.*

*With **Aspect**, the aspect ratio of the source is maintained: in the above mentioned example, the pixels both in horizontal and in vertical direction would be multiplied by a factor of two, thus the content would have a black border of 240 pixels both, on the left side and on the right side.*

4:3: if a PAL/NTSC source is connected to an input, the 4:3 setting displays the source without any distortion (e.g. a circle remains a circle).

RCU	Push button (1: top most)
<ul style="list-style-type: none"> Use the up and down cursor keys to navigate to the Scaling 	<ul style="list-style-type: none"> Press 5 and 6 to navigate to Scaling
<ul style="list-style-type: none"> Use the left and right cursor keys to select one of the options Native, Fill, Aspect, 4:3. The current selection is visualized by a white caption. 	<ul style="list-style-type: none"> Use 3 and 4 to select one of the options Native, Fill, Aspect, 4:3. The current selection is visualized by a white caption.
The selection is applied without any further action.	

Adaptive Deinterlacing

Adaptive deinterlacing can be selected to off, level 1, level 2, level 3.

Select the appropriate level of adaptive deinterlacing to optimize the quality of the video.

RCU	Push button (1: top most)
<ul style="list-style-type: none"> Use the up and down cursor keys to navigate to the Adaptive Deinterlacing 	<ul style="list-style-type: none"> Press 5 and 6 to navigate to Adaptive Deinterlacing
<ul style="list-style-type: none"> Use the left and right cursor keys to select one of the options Off, Level 1, Level 2, Level 3. The current selection is visualized by a white caption. 	<ul style="list-style-type: none"> Use 3 and 4 to select one of the options Off, Level 1, Level 2, Level 3. The current selection is visualized by a white caption.
The selection is applied without any further action.	

Noise Reduction

Noise reduction can be selected to off, low, medium, or high.

*Noise is generally visible as "snow", or small dots that make the picture look fuzzy, With **Noise Reduction** the amount of noise attenuation can be specified.*

RCU	Push button (1: top most)
<ul style="list-style-type: none"> Use the up and down cursor keys to navigate to the Noise Reduction 	<ul style="list-style-type: none"> Press 5 and 6 to navigate to Noise Reduction
<ul style="list-style-type: none"> Use the left and right cursor keys to select one of the options Off, Low, Medium, High The current selection is visualized by a white caption. 	<ul style="list-style-type: none"> Use 3 and 4 to select one of the options Off, Low, Medium, High The current selection is visualized by a white caption.
<p>The selection is applied without any further action.</p>	

Angle Filtering

Angle filtering can be selected to on or off.

RCU	Push button (1: top most)
<ul style="list-style-type: none"> Use the up and down cursor keys to navigate to the Angle Filtering 	<ul style="list-style-type: none"> Press 5 and 6 to navigate to Angle Filtering
<ul style="list-style-type: none"> Use the left and right cursor keys to select one of the options Off, On The current selection is visualized by a white caption. 	<ul style="list-style-type: none"> Use 3 and 4 to select one of the options Off, On The current selection is visualized by a white caption.
<p>The selection is applied without any further action.</p>	

Film Mode Detect

Film Mode Detect can be selected to be on or off.

Film is usually recorded at 24 frames per second. When converting film to NTSC video (59.94 Hz field rate), 2 film frames generate 5 video fields (3:2 pull down). Film scenes with high-speed motion objects thus may show motion artifacts.

*With **Film Mode Detect** on, the conversion to NTSC is detected and the original film frames are recreated by blending the fields back together.*

(3:2 pull down is only one of the pull down techniques and used as an example)

RCU	Push button (1: top most)
<ul style="list-style-type: none"> Use the up and down cursor keys to navigate to the Film Mode Detect 	<ul style="list-style-type: none"> Press 5 and 6 to navigate to Film Mode Detect
<ul style="list-style-type: none"> Use the left and right cursor keys to select one of the options Off, On The current selection is visualized by a white caption. 	<ul style="list-style-type: none"> Use 3 and 4 to select one of the options Off, On The current selection is visualized by a white caption.
The selection is applied without any further action.	



This function may cause undesired effects on standard sources, therefore it can be disabled (OFF) at any time.

Sharpness

Sharpness can be set in the range from -15 to +29





The edges are localized and the contrast between neighboring pixels enhanced.

RCU	Push button (1: top most)
<ul style="list-style-type: none"> Use the up and down cursor keys to navigate to the Sharpness 	<ul style="list-style-type: none"> Press 5 and 6 to navigate to Sharpness
<ul style="list-style-type: none"> Use the left and right cursor keys to increase/decrease the value in steps of 1 The current value is indicated. 	<ul style="list-style-type: none"> Use 3 and 4 to increase/decrease the value in steps of 1 The current value is indicated.
The value is applied without any further action.	

5.3.6 Color

On the **Color** dialog, the gamma correction factor can be selected as well as the color temperature.

To activate the **Color** dialog, proceed as follows:

RCU	Icon	Push button (1: top most)
<ul style="list-style-type: none"> Press the ADJ key to activate the OSD 		<ul style="list-style-type: none"> Press 7 to activate the OSD
<ul style="list-style-type: none"> Use the left and right cursor keys to navigate to the signal menu 		<ul style="list-style-type: none"> Press 3 and 4 to navigate to the signal menu
<ul style="list-style-type: none"> Press Enter to select 		<ul style="list-style-type: none"> Press 2 to select
<ul style="list-style-type: none"> Use the left and right cursor keys to navigate to Color 		<ul style="list-style-type: none"> Press 3 and 4 to navigate to Color
<ul style="list-style-type: none"> Press Enter to select – or – Press the down key to activate the dialog 		<ul style="list-style-type: none"> Press 2 to select – or – Press 5 to activate the dialog

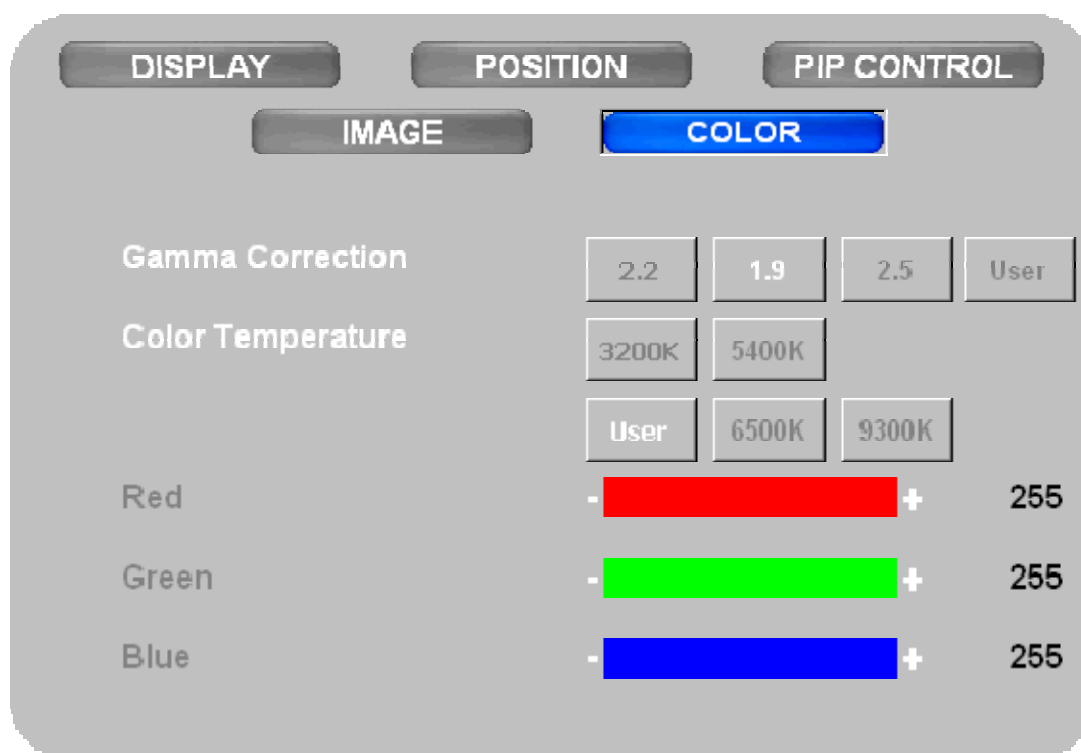
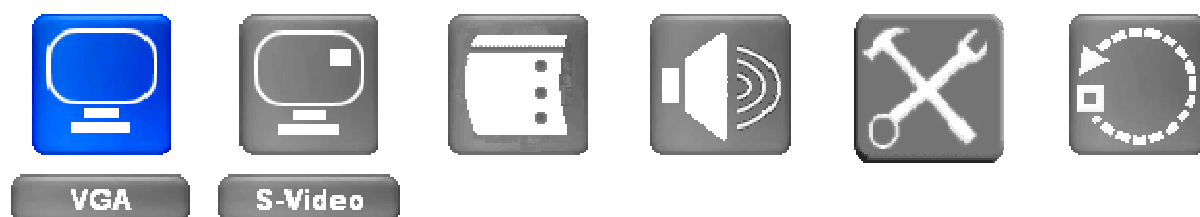

5.3.6.1 Gamma Correction

The Gamma correction factor can be set to 2.2, 1.9, 2.5, and user.

Gamma is the relationship between the color values of the data and the color values displayed e.g. on a screen. The Gamma coefficient makes it possible to adjust the brightness of the midtones only without affecting the very bright and very dark areas..

If gamma is set too high, middle tones appear too dark. If it's set too low, middle tones appear too light.

Using Barco's DCMS software (display consistency management software), the monitor can be calibrated and the calibrated setting (look-up table, LUT) can be saved in the monitor. The gamma setting "user" activates the last calibrated value.

RCU	Push button (1: top most)
<ul style="list-style-type: none"> Use the up and down cursor keys to navigate to the Gamma Correction 	<ul style="list-style-type: none"> Press 5 and 6 to navigate to Gamma Correction
<ul style="list-style-type: none"> Use the left and right cursor keys to select one of the options 2.2, 1.9, 2.5, user. The current selection is visualized by a white caption. 	<ul style="list-style-type: none"> Use 3 and 4 to select one of the options 2.2, 1.9, 2.5, user. The current selection is visualized by a white caption.
The selection is applied without any further action.	

5.3.6.2 Color Temperature

Color temperature can be selected to be 3200K, 5400K, 6500K, 9300K or custom (User, requires to adjust the values for red, green, and blue).

Color temperature stands for the spectral properties of a light source.

Low color temperature implies warmer (more yellow/red) light while high color temperature implies a colder (more blue) light.

The pictures of a monitor set to 9300K will look more bluish than if set to 3200K.

The following color temperature pre-sets can be selected:

Color temperature	name / application
3200K	Broadcast
5400K	Film
6500K	Video
9300K	Computer
User	custom

RCU	Push button (1: top most)
<ul style="list-style-type: none"> Use the up and down cursor keys to navigate to the Color Temperature 	<ul style="list-style-type: none"> Press 5 and 6 to navigate to Color Temperature
<ul style="list-style-type: none"> Use the left and right cursor keys to select one of the options 3200K, 5400K, User, 6500K, 9300K. The current selection is visualized by a white caption. 	<ul style="list-style-type: none"> Use 3 and 4 to select one of the options 3200K, 5400K, User, 6500K, 9300K. The current selection is visualized by a white caption.
The selection is applied without any further action.	

When **User** is selected, the values for red, green, blue can be individually be adjusted:

RCU	Push button (1: top most)
<ul style="list-style-type: none">Use the up and down cursor keys to navigate to the Color Temperature	<ul style="list-style-type: none">Press 5 and 6 to navigate to Color Temperature
<ul style="list-style-type: none">Use the left and right cursor keys to select User	<ul style="list-style-type: none">Use the left and right cursor keys to select User
<ul style="list-style-type: none">Use the down and up cursor keys to select Red, Green, Blue	<ul style="list-style-type: none">Use the 5 and 6 to select Red, Green, Blue
<ul style="list-style-type: none">Use the left and right cursor keys to increase/decrease the value in steps of 1 The current value is indicated.	<ul style="list-style-type: none">Use 3 and 4 to increase/decrease the value in steps of 1 The current value is indicated.

The selection is applied without any further action.



Manual modification of R, G, B requires some experience!





In case a VGA signal looks e.g. greenish, pressing the function key F4 (White balance) will probably correct this. Thus no sophisticated color adjustment will be required.

5.4 OSD setting menu

On the **OSD** dialog, the position of the OSD can be defined as well as zoom, blend and time out of the OSD.

To activate the **OSD** menu, proceed as follows:

RCU	Icon	Push button (1: top most)
<ul style="list-style-type: none"> Press the ADJ key to activate the OSD 		<ul style="list-style-type: none"> Press 7 to activate the OSD
<ul style="list-style-type: none"> Use the cursor keys to navigate to the OSD setting menu 		<ul style="list-style-type: none"> Press 3 and 4 to navigate to the OSD setting menu
<ul style="list-style-type: none"> The icon will turn blue, and the setting dialog will pop up 		<ul style="list-style-type: none"> The icon will turn blue, and the setting dialog will pop up

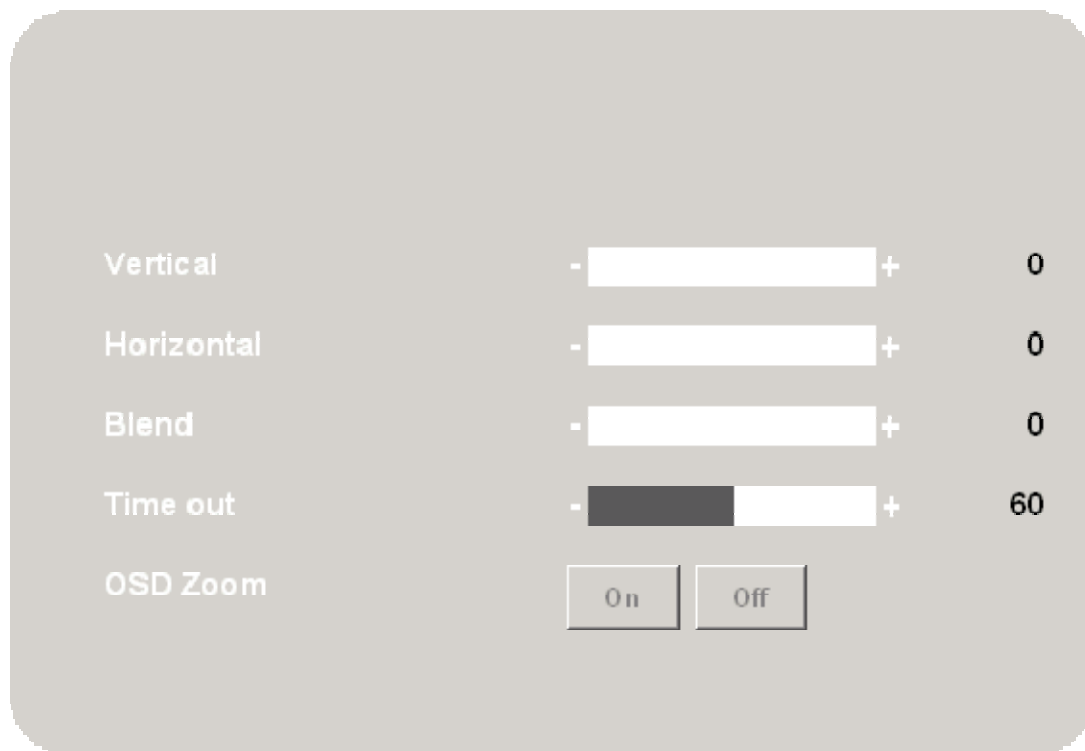
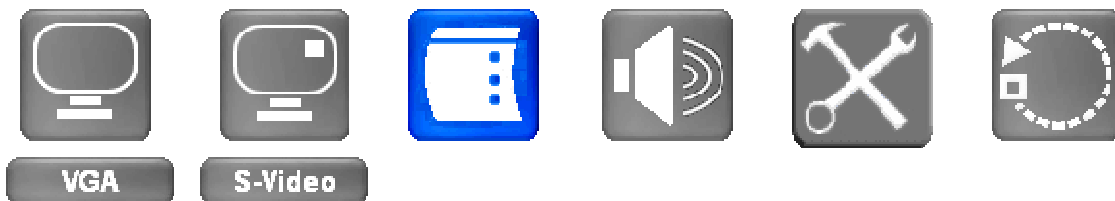

Each time the OSD opens, its position and behavior will be as set on this dialog.

5.4.1 Vertical

The value can be set in the range from 0 to 255 (zero: top of OSD is level with top of monitor, 255: bottom of OSD is level with bottom of monitor).

RCU	Push button (1: top most)
<ul style="list-style-type: none"> Use the up and down cursor keys to navigate to the Vertical 	<ul style="list-style-type: none"> Press 5 and 6 to navigate to Vertical
<ul style="list-style-type: none"> Use the left and right cursor keys to increase/decrease the value in steps of 1. The current value is indicated. (increase: move down) 	<ul style="list-style-type: none"> Use 3 and 4 to increase/decrease the value in steps of 1. The current value is indicated. (increase: move down)
The value is applied without any further action.	



Vertical and Horizontal define the position of the OSD. Whenever the OSD is activated, it will be displayed at the position defined by the vertical and horizontal setting.

5.4.2 Horizontal

The value can be set in the range from 0 to 255 (zero: left of OSD is level with left of monitor, 255: right of OSD is level with right of monitor).

RCU	Push button (1: top most)
<ul style="list-style-type: none"> Use the up and down cursor keys to navigate to the Horizontal 	<ul style="list-style-type: none"> Press 5 and 6 to navigate to Horizontal
<ul style="list-style-type: none"> Use the left and right cursor keys to increase/decrease the value in steps of 1. The current value is indicated. (increase: move right) 	<ul style="list-style-type: none"> Use 3 and 4 to increase/decrease the value in steps of 1. The current value is indicated. (increase: move right)
The value is applied without any further action.	

5.4.3 Blend

The value can be set in the range from 0 to 15 (zero: opaque, 15: transparent)

Use **Blend** to set the transparency of the OSD: when it **Blend** is set to zero, the background of the OSD will be opaque thus entirely hiding the screen content at this position. To make the screen content visible in spite of the overlaying OSD, increase the **Blend** parameter!

RCU	Push button (1: top most)
<ul style="list-style-type: none"> Use the up and down cursor keys to navigate to the Blend 	<ul style="list-style-type: none"> Press 5 and 6 to navigate to Blend
<ul style="list-style-type: none"> Use the left and right cursor keys to increase/decrease the value in steps of 1. The current value is indicated. 	<ul style="list-style-type: none"> Use 3 and 4 to increase/decrease the value in steps of 1. The current value is indicated.
The value is applied without any further action.	

5.4.4 Time out

The value can be set between 0 and 60 seconds in steps of 5 seconds.

*The OSD will close (disappear) automatically when no selections are made during a certain time. This period can be set by means of the **Time out** parameter.*



The OSD stays active as long as it is in use.

Independent from the Time out setting, you can close the OSD at any time by using the Exit button the RCU or the push button 7 on the right rear side of the monitor.

RCU	Push button (1: top most)
<ul style="list-style-type: none"> Use the up and down cursor keys to navigate to the Time out 	<ul style="list-style-type: none"> Press 5 and 6 to navigate to Time out
<ul style="list-style-type: none"> Use the left and right cursor keys to increase/decrease the value in steps of 5 The current value is indicated. 	<ul style="list-style-type: none"> Use 3 and 4 to increase/decrease the value in steps of 5 The current value is indicated.
The value is applied without any further action.	

5.4.5 OSD Zoom

Zoom can be selected in or out.



This command will magnify the OSD window and the icons by approx. the factor of 2.

RCU	Push button (1: top most)
<ul style="list-style-type: none"> Use the up and down cursor keys to navigate to the OSD Zoom 	<ul style="list-style-type: none"> Press 5 and 6 to navigate to OSD Zoom
<ul style="list-style-type: none"> Use the left and right cursor keys to select one of the options In, Out The current selection is visualized by a white caption. 	<ul style="list-style-type: none"> Use 3 and 4 to select one of the options In, Out The current selection is visualized by a white caption.
<ul style="list-style-type: none"> Apply the selection with Enter. 	<ul style="list-style-type: none"> Apply the selection with 2
This selection has to be confirmed to be applied.	

5.5 Audio setting menu

On the **Audio setting** menu, the volume and the balance of the left/right speaker can be adjusted as well as bass and treble (low frequencies and high frequencies).

To activate the **Audio setting** menu, proceed as follows:

RCU	Icon	Push button (1: top most)
<ul style="list-style-type: none"> Press the ADJ key to activate the OSD 		<ul style="list-style-type: none"> Press 7 to activate the OSD
<ul style="list-style-type: none"> Use the cursor keys to navigate to the Audio setting menu 		<ul style="list-style-type: none"> Press 3 and 4 to navigate to the Audio setting menu
<ul style="list-style-type: none"> The icon will turn blue, and the setting dialog will pop up 		<ul style="list-style-type: none"> The icon will turn blue, and the setting dialog will pop up

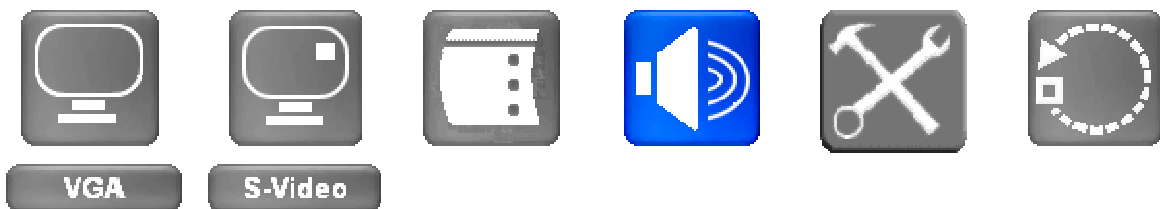

5.5.1 Volume

Volume can be adjusted in the range from 0 to 79.



Use the push button 3 on the right rear side of the monitor to directly increase the volume, use the push button 4 to directly decrease the volume.

RCU	Push button (1: top most)
<ul style="list-style-type: none"> Use the up and down cursor keys to navigate to the Volume 	<ul style="list-style-type: none"> Press 5 and 6 to navigate to Volume
<ul style="list-style-type: none"> Use the left and right cursor keys to increase/decrease the value in steps of 1 The current value is indicated. 	<ul style="list-style-type: none"> Use 3 and 4 to increase/decrease the value in steps of 1 The current value is indicated.
The value is applied without any further action.	

5.5.2 Balance

Balance can be adjusted in the range from -15 to +15.

The zero position is in the center of the slider. In case the left and the right speaker are not balanced, i.e. one side is predominant, adjust the setting in negative direction to bring out the left speaker, in positive direction to bring out the right speaker.

RCU	Push button (1: top most)
<ul style="list-style-type: none"> Use the up and down cursor keys to navigate to the Balance 	<ul style="list-style-type: none"> Press 5 and 6 to navigate to Balance
<ul style="list-style-type: none"> Use the left and right cursor keys to increase/decrease the value in steps of 1 The current value is indicated. 	<ul style="list-style-type: none"> Use 3 and 4 to increase/decrease the value in steps of 1 The current value is indicated.
The value is applied without any further action.	

5.5.3 Bass

Bass can be adjusted in the range from -7 to +7.

The zero position is in the center of the slider. In case the low frequencies are predominant, adjust the slider to the left. In case they are rather faint or missing, adjust the slider to the right,

RCU	Push button (1: top most)
<ul style="list-style-type: none"> Use the up and down cursor keys to navigate to the Bass 	<ul style="list-style-type: none"> Press 5 and 6 to navigate to Bass
<ul style="list-style-type: none"> Use the left and right cursor keys to increase/decrease the value in steps of 1 The current value is indicated. 	<ul style="list-style-type: none"> Use 3 and 4 to increase/decrease the value in steps of 1 The current value is indicated.
The value is applied without any further action.	

5.5.4 Treble

Treble can be adjusted in the range from -7 to +7.



The zero position is in the center of the slider. In case the high frequencies are predominant, adjust the slider to the left. In case they are rather faint or missing, adjust the slider to the right.

RCU	Push button (1: top most)
<ul style="list-style-type: none">Use the up and down cursor keys to navigate to the Treble	<ul style="list-style-type: none">Press 5 and 6 to navigate to Treble
<ul style="list-style-type: none">Use the left and right cursor keys to increase/decrease the value in steps of 1 The current value is indicated.	<ul style="list-style-type: none">Use 3 and 4 to increase/decrease the value in steps of 1 The current value is indicated.
The value is applied without any further action.	

5.6 Display parameter setting menu

On the **Display parameter setting** menu, setting of display address, baud rate, light sensor, lower brightness level, ambient light threshold & auto source selection can be done.

To activate the **Display parameter setting** menu, proceed as follows:

RCU	Icon	Push button (1: top most)
<ul style="list-style-type: none"> Press the ADJ key to activate the OSD 		<ul style="list-style-type: none"> Press 7 to activate the OSD
<ul style="list-style-type: none"> Use the cursor keys to navigate to the Display parameter setting menu 		<ul style="list-style-type: none"> Press 3 and 4 to navigate to the Display parameter setting menu
<ul style="list-style-type: none"> The icon will turn blue, and the setting dialog will pop up 		<ul style="list-style-type: none"> The icon will turn blue, and the setting dialog will pop up

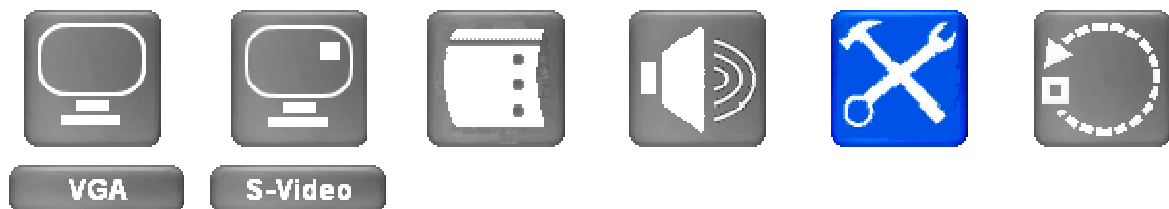
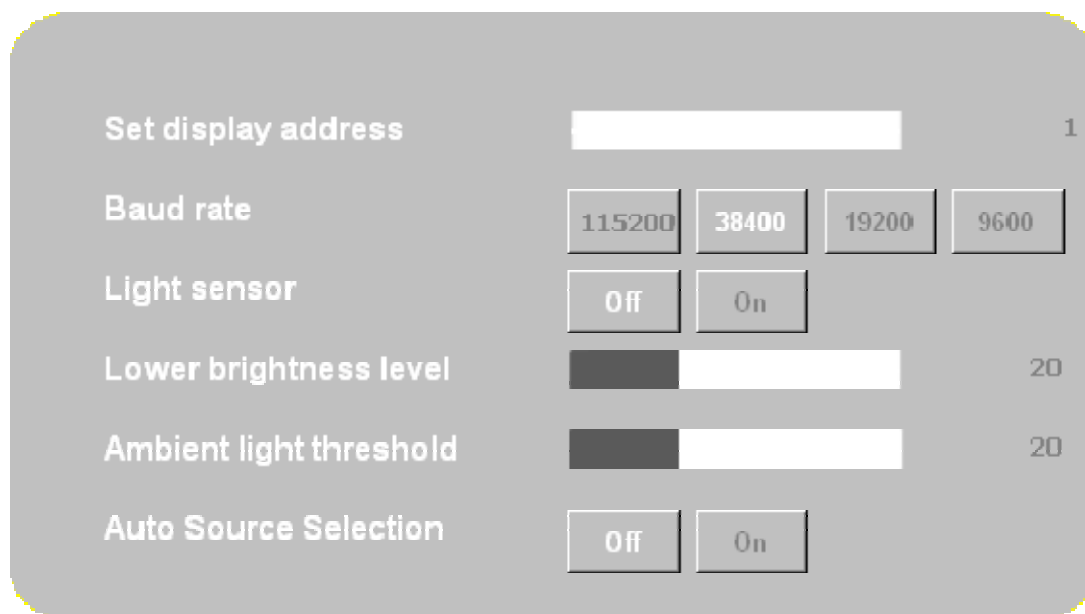
The screenshot shows the 'Display parameter setting' menu with the following options:

- Set display address**: A text input field with the value '1' on the right.
- Baud rate**: Four buttons labeled '115200', '38400', '19200', and '9600'.
- Light sensor**: Two buttons labeled 'Off' and 'On'.
- Lower brightness level**: A horizontal slider bar with '20' on the right.
- Ambient light threshold**: A horizontal slider bar with '20' on the right.
- Auto Source Selection**: Two buttons labeled 'Off' and 'On'.

To select a display parameter; proceed as follows:

RCU	Push button (1: top most)
<ul style="list-style-type: none"> Use the up and down cursor keys to navigate to the desired parameter 	<ul style="list-style-type: none"> Press 5 and 6 to navigate to the desired parameter
<ul style="list-style-type: none"> Use the left and right cursor keys to activate the desired value. The current selection is visualized by a white caption. 	<ul style="list-style-type: none"> Use 3 and 4 to activate the desired value <p>The current selection is visualized by a white caption.</p>
The selection is applied without any further action.	

5.6.1 Set display address

The value can be set in the range from 1 to 255.

If more than one monitor is installed, the monitors can independently be RS232 remote-controlled by means of their display address.

Default monitor address is "1". Allowed addresses are in the range from 1 to 255.

"1" is the common address.

A monitor will listen to the commands explicitly sent to his specific address and to commands sent to the common address.

RCU	Push button (1: top most)
<ul style="list-style-type: none"> Use the up and down cursor keys to navigate to the Set display address 	<ul style="list-style-type: none"> Press 5 and 6 to navigate to Set display address
<ul style="list-style-type: none"> Use the left and right cursor keys to increase/decrease the address in steps of 1. The current value is indicated. 	<ul style="list-style-type: none"> Use 3 and 4 to increase/decrease the address in steps of 1. The current value is indicated.
The value is applied without any further action.	

5.6.2 Baud rate

The value can be set to 115200, 38400, 19200, 9600.

RCU	Push button (1: top most)
<ul style="list-style-type: none"> Use the up and down cursor keys to navigate to the Baud rates 	<ul style="list-style-type: none"> Press 5 and 6 to navigate to Baud rate
<ul style="list-style-type: none"> Use the left and right cursor keys to select one of the options 115200, 38400, 19200, 9600. The current selection is visualized by a white caption 	<ul style="list-style-type: none"> Use 3 and 4 to select one of the options 115200, 38400, 19200, 9600. The current selection is visualized by a white caption
The value is applied without any further action.	

5.6.3 Light Sensor

The light sensor can be set on or off.

When a room is dark, the picture content can be viewed at lower brightness (power saving, avoiding eye fatigue). If enabled, the light sensor measures the ambient light, and if the room gets dark enough, the monitor will be switched to the "dark mode" with a brightness set via the Light Sensor Value.

RCU	Push button (1: top most)
<ul style="list-style-type: none"> Use the up and down cursor keys to navigate to the Light Sensor 	<ul style="list-style-type: none"> Press 5 and 6 to navigate to Light Sensor
<ul style="list-style-type: none"> Use the left and right cursor keys to select one of the options Off, On The current selection is visualized by a white caption. 	<ul style="list-style-type: none"> Use 3 and 4 to select one of the options Off, On The current selection is visualized by a white caption.
The selection is applied without any further action.	

5.6.4 Lower brightness level

The lower brightness level value can be set in the range from 0 to 100.

This parameter defines the brightness the monitor is automatically switched to when the ambient light is below the threshold of the light sensor (dark mode, requires that the light sensor is set On!)

RCU	Push button (1: top most)
<ul style="list-style-type: none"> Use the up and down cursor keys to navigate to the Lower brightness level 	<ul style="list-style-type: none"> Press 5 and 6 to navigate to Lower brightness level
<ul style="list-style-type: none"> Use the left and right cursor keys to increase/decrease the value in steps of 1 The current value is indicated. 	<ul style="list-style-type: none"> Use 3 and 4 to increase/decrease the value in steps of 1 The current value is indicated.
The value is applied without any further action.	

5.6.5 Ambient light threshold

The ambient light threshold can be set in the range from 0 to 100.

This parameter defines the ambient light level below which the monitor will switch to a low backlight mode. (dark mode, requires that the light sensor is set On!)

RCU	Push button (1: top most)
<ul style="list-style-type: none"> Use the up and down cursor keys to navigate to the Ambient light threshold 	<ul style="list-style-type: none"> Press 5 and 6 to navigate to Ambient light threshold.
<ul style="list-style-type: none"> Use the left and right cursor keys to increase/decrease the value in steps of 1 The current value is indicated. 	<ul style="list-style-type: none"> Use 3 and 4 to increase/decrease the value in steps of 1 The current value is indicated.
The value is applied without any further action.	

5.6.6 Auto Source Selection



The Auto Source Selection can be set on or off.

When Auto Source Selection is on, the system searches for a valid input source signal.

RCU	Push button (1: top most)
<ul style="list-style-type: none">• Use the up and down cursor keys to navigate to Auto Source Selection	<ul style="list-style-type: none">• Press 5 and 6 to navigate to Auto Source Selection
<ul style="list-style-type: none">• Use the left and right cursor keys to select one of the options Off, On The current selection is visualized by a white caption.	<ul style="list-style-type: none">• Use 3 and 4 to select one of the options Off, On The current selection is visualized by a white caption.
The selection is applied without any further action.	

5.7 Reset menu

On the **Reset** menu, the factory settings can be restored. It also shows runtime & serial number of the display. To activate the **Reset** menu, proceed as follows:

RCU	Icon	Push button (1: top most)
<ul style="list-style-type: none"> Press the ADJ key to activate the OSD 		<ul style="list-style-type: none"> Press 7 to activate the OSD
<ul style="list-style-type: none"> Use the cursor keys to navigate to the Reset menu 		<ul style="list-style-type: none"> Press 3 and 4 to navigate to the Reset menu
<ul style="list-style-type: none"> The icon will turn blue, and the setting dialog will pop up 		<ul style="list-style-type: none"> The icon will turn blue, and the setting dialog will pop up

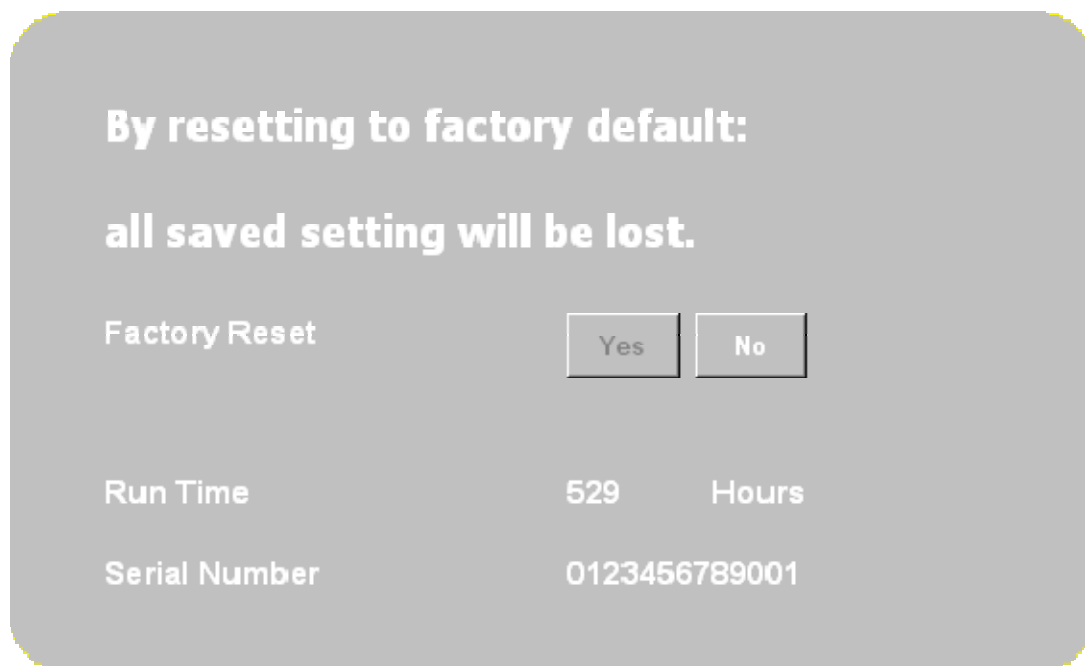
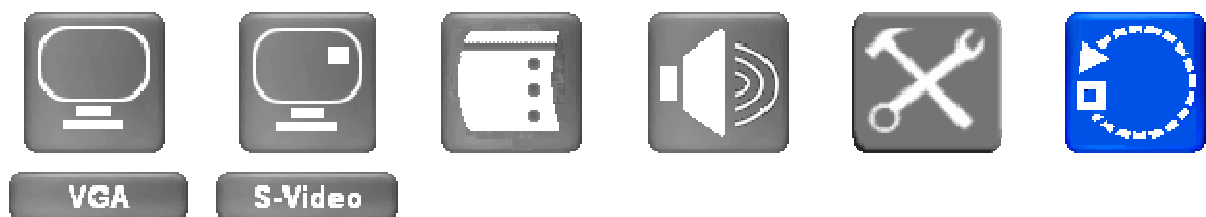

5.7.1 Factory Reset



Clicking the button Yes on the option Factory Reset will inevitably reset the monitor to its factory settings.

All former adjustment and modifications will be lost!



These are the factory settings which are applied after selecting **Yes** with **Factory Reset**:

Item	default	adjust range
Power switch	Off	On/Off
Brightness	80	0~100
Contrast	50	0~100
Color temp.	User	User, 3200K,5400K,6500K, 9300K
Red	255	0~255
Green	255	0~255
Blue	255	0~255
Language	English	English
Auto configuration	On	On/Off

RCU	Push button (1: top most)
<ul style="list-style-type: none"> Use the up and down cursor keys to navigate to the Factory Reset 	<ul style="list-style-type: none"> Press 5 and 6 to navigate to Factory Reset
<ul style="list-style-type: none"> Use the left and right cursor keys to select one of the options Yes, No The current selection is visualized by a white caption. 	<ul style="list-style-type: none"> Use 3 and 4 to select one of the options Yes, No The current selection is visualized by a white caption.
The selection is applied without any further action.	

5.8 Input Signal Selection

In case multiple sources are connected, the signal for the first input and the second input have to be defined. To select the signal for the respective input, proceed as follows:

RCU	Icon	Push button (1: top most)
<ul style="list-style-type: none"> Press the ADJ key to activate the OSD 		<ul style="list-style-type: none"> Press 7 to activate the OSD
<ul style="list-style-type: none"> Use the left and right cursor keys to navigate to the signal menu (for the first input) 		<ul style="list-style-type: none"> Press 3 and 4 to navigate to the signal (for the first menu input)
<ul style="list-style-type: none"> Press Enter to select 		<ul style="list-style-type: none"> Press 2 to select
<ul style="list-style-type: none"> Use the down cursor keys to open the input signal selection dialog 		<ul style="list-style-type: none"> Press 4 to open the input signal selection dialog

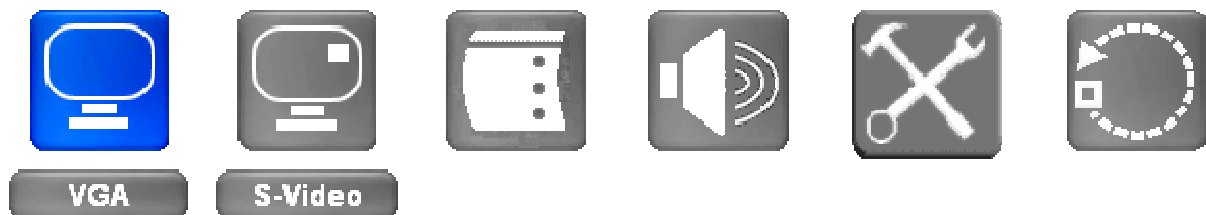

After the source has been selected, its timing is displayed.





In case the timing of the source is not included in the presets of the monitor, the timing of the monitor which matches best the timing of the source is displayed!

The following sources can be connected to the monitor:

Input		Interface	signals
Video system input	VIDEO IN	RCA	NTSC/PAL
	S-VIDEO	S-Video Mini Din 4pin	NTSC/PAL
	YUV (Y Pb/Cb Pr/Cr)	Component Mini Din 8 pin	NTSC/PAL
RGB input	RGB Analog	D-Sub 15 pin	RGB analog
	RGB Digital	DVI-D 24 pin	RGB digital
HD-SDI input	Serial Digital	BNC	SDI / HSDI

To select a signal, proceed as follows:

RCU	Icon	Push button (1: top most)
<ul style="list-style-type: none"> Press the ADJ key to activate the OSD 		<ul style="list-style-type: none"> Press 7 to activate the OSD
<ul style="list-style-type: none"> Use the left and right cursor keys to navigate to the signal menu 		<ul style="list-style-type: none"> Press 3 and 4 to navigate to the signal menu
<ul style="list-style-type: none"> Press Enter to select 		<ul style="list-style-type: none"> Press 2 to select
<ul style="list-style-type: none"> Use the down cursor keys to open the input signal selection dialog 		<ul style="list-style-type: none"> Press 4 to open the input signal selection dialog
<ul style="list-style-type: none"> Use the left and right cursor keys to select the desired signal 		<ul style="list-style-type: none"> Press 3 and 4 to select the desired signal



In case the signal is assigned to input 1, it cannot be assigned to input 2!

To change the signal of input 1 and input 2, input 1 has to be assigned to the signal which up to then has been assigned to input 2.

In case of two valid signals, input 2 then will automatically be assigned to the signal which up to then has been assigned to input 1.

In case of more signals, input 2 has to be explicitly assigned to a signal (all but the one assigned to input 1).



To select HD-SDI input 1 or HD-SDI input 2, first select HD-SDI in the OSD. When it is highlighted, press 1 to select the signal connected to HD-SDI input 1, or press 2 to select the signal connected to HD-SDI input 2.

In case no signal is applied, the monitor displays a "no sync" message.

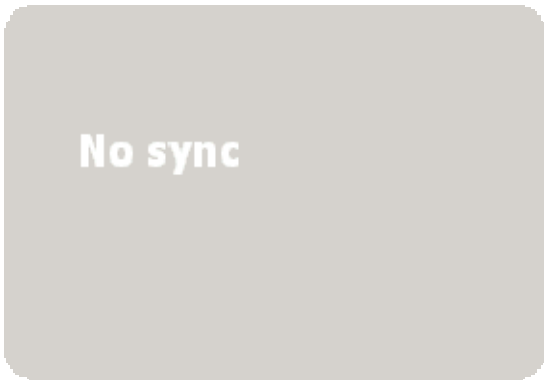

In case no cable is connected, the monitor displays a "no cable" message.

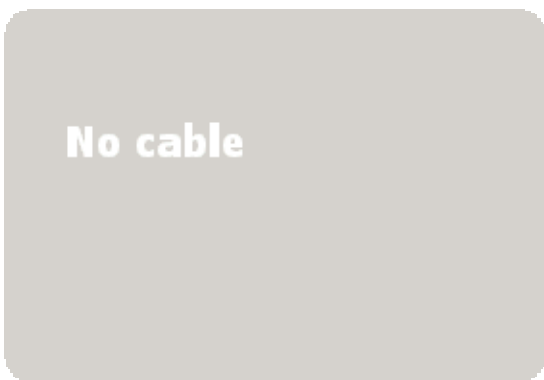

In case the timing of the connected source is not compliant to the monitor, the monitor displays a "invalid mode" message.

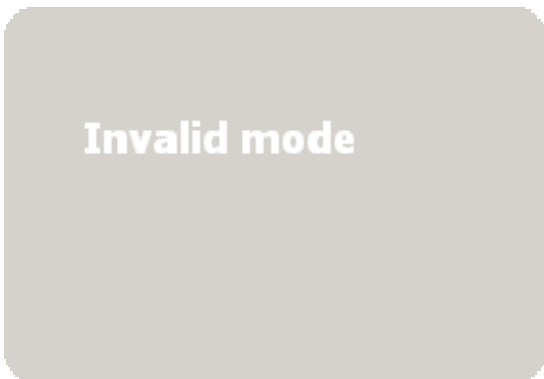

For a list of compliant timings, cf. [chapter 9 Compliant timing](#)



The monitor features autodetect. In case e.g. DVI is selected, but the only connected source is VGA, the monitor will display the no sync message, and after a while automatically switch to VGA.

5. The On Screen Display (OSD)

If no source is connected (neither no sync, no cable, no valid signal), the monitor switches to standby and displays the respective information:

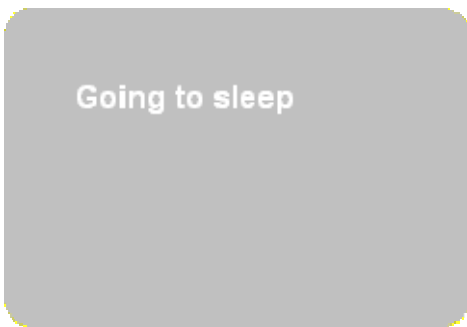

Whenever one of these messages pop up, check the respective item and fix it!

5.8.1 Input selection with the function key F1

For input 1, the input can be selected using the function key **F1**. Pressing **F1** "scrolls" through the inputs and displays one after the other the respective icon.



Press **Enter** to directly select the desired input.

6 Maintenance and servicing



Only authorized personnel should carry out other maintenance work not explicitly mentioned in this manual!

Never open the case of the monitor without first disconnecting the power supply cord! Measurements and tests with the opened device may be carried out only in the factory or by specially trained personnel, due to the dangers of electrical shock.

6.1 Cleaning

Consult your dealer for internal cleaning once a year.

If you allow dust to accumulate on the unit, it may cause fire or malfunction when you operate it.

Refer to your dealer about the internal cleaning.

Power plug

If dust has collected on the power plug connectors, remove the plug from the outlet and clean off the dust. This dust may cause a fire due to reduced insulation of the plug.

Cabinet

Unplug this product from the wall outlet before cleaning. Do not use liquid cleaners or aerosol cleaners. Use a damp cloth for cleaning. To keep the cabinet looking brand-new, periodically clean it with a soft cloth. Stubborn stains may be removed with a cloth lightly dampened with mild detergent solution. Never use strong solvents, such as thinner or benzene, or abrasive cleaners, since these will damage the cabinet.

Contamination of screen surface.

When the screen surface of the monitor is contaminated, please wipe the surface softly with cotton swab or clean cloth. If it is not enough, please take it away with cellophane tape or wipe the surface with cotton swab or clean cloth containing solvent of 50% alcohol. In this case, please be careful so that the solvent does not get in inside of the LCD module, because it may be damaged.

Water drop on LCD surface

Please do not leave LCD module with water drop. When the display surface gets water drop, please wipe it off with cotton swab or soft cloth immediately, otherwise display surface will be deteriorated. If water gets in inside the LCD module, the electric circuits may be damaged.

7 Technical data 42" version (LCN-42, LCS-42)

7.1 General data

characteristic	specification
Screen size	42" diagonal
Aspect ratio	16:9
active area (HxW)	934mm x 527mm 36.77in. x 20.75in.
width x height x depth (without stand!)	1026mm x 619mm x 123.7mm 40.39in. x 24.37in. x 4.87in.
weight	29.5kg 65.1lbs

Table 7-1

7.2 LCD panel

characteristic	specification
Driver element	a-Si TFT active matrix
Pixel number	(1920 x R.G.B. x 1080) pixel (HDTV)
Display colors	16.8 millions of colors
Viewing angle	176 degree vertical / 176 degree horizontal
Brightness	500 cd/m ²
Contrast ratio	1800:1
Response time (Gray to Gray)	Typ. 6.5 msec, max. 12msec
Interfaces	VGA (D-Sub 15 pins), DVI (DVI-D 24 pins), Composite (RCA), S-Video (Mini-DIN 4 pin), Component (Mini-DIN 8 pin), SDI/HD-SDI in/out (BNC), RS232 IN/OUT (D-Sub 9)
Dead pixel rate	Max. 8 bright pixels out of which max. 2 clusters of two bright pixels. Max.10 dark pixels out of which max. 5 clusters of two dark pixels

Table 7-2

7.3 Electrical data

Characteristic	specification
Power supply	100VAC-240 VAC, 50/60 Hz
Power consumption operating mode	234W 116 BTU/h
Power consumption Standby mode	14.8W 50.5 BTU/h

Table 7-3

7.4 Operating conditions

Characteristic	specification
Storage temperature	-20°C - +60°C -4°F - 140°F, at max. 90% RH, non-condensing
Operating ambient temperature	+5°C - +40°C 41°F - 104°F, at max. 90% RH, non-condensing

Table 7-4

7.5 CCFL (Cold Cathode Fluorescent Lamp) characteristics (ambient temperature (25 ±2)°C)

Characteristic	Typ. value
Lamp voltage	1520 VRMS
Lamp current	5.8 mARMS
Lamp starting voltage	2370 VRMS (0°C), 2160 VRMS (25°C)
Lamp life time	50,000hrs *)
Operating frequency	40-70 KHz

Table 7-5

The life time of a lamp is defined as when the brightness is larger than 50% of its original value and the effective discharge length is longer than 80% of its original length.

7.6 Interfaces

7.6.1 Video IN (Composite Video)

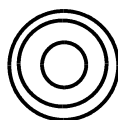

Item	specification
Signal level	1.0Vpp
Connector type	RCA Jack
Termination	75Ω

Table 7-6

7.6.2 S-Video



Item	specification
1,2	Ground
3	Y
4	C
Luminance level	1.0 Vpp
Color level	0.286 Vpp
Connector type	Mini Din 4pin
Termination	75Ω

Table 7-7

7.6.3 Component Video (mini DIN 8 pin)



Item	specification	Item	specification
1	GND	5	GND
2	CB	6	CR
3	GND	7	not connected
4	Y	8	not connected
Connector type		Mini Din 8pin	
Termination		75Ω	

Table 7-8

		White	Yellow	Cyan	Green	Magenta	Red	Blue	Black
Y	IRE	75	69.5	59.1	53.6	21.4	15.9	5.4	0
	mV	525	487	413	375	150	112	38	0
Pb	IRE	0	-37.5	8.6	-28.9	28.9	-8.6	37.5	0
	mV	0	-263	60	-202	202	-60	263	0
Pr	IRE	0	3.4	-37.5	-34.1	34.1	37.5	-3.4	0
	mV	0	24	-263	-238	238	263	-24	0

Table 7-9

HDTV YPbPr 75% color bars. Values are relative to the blanking level.

		White	Yellow	Cyan	Green	Magenta	Red	Blue	Black
Y	IRE	100	92.8	78.7	71.5	28.5	21.3	7.2	0
	mV	700	649	551	501	199	149	51	0
Pb	IRE	0	-50	11.5	-38.5	38.5	-11.5	50	0
	mV	0	-350	80	-270	270	-80	350	0
Pr	IRE	0	4.6	-50	-45.4	45.4	50	-4.6	0
	mV	0	32	-350	-318	318	350	-32	0

Table 7-10

HDTV YPbPr 100% color bars. Values are relative to the blanking level.

		White	Yellow	Cyan	Green	Magenta	Red	Blue	Black
Y	IRE	75	66.5	52.6	44.0	31.0	22.4	8.6	0
	mV	525	465	368	308	217	157	60	0
Cb	IRE	0	-37.5	12.7	-24.8	24.8	-12.7	37.5	0
	mV	0	-263	89	-174	174	-89	263	0
Cr	IRE	0	6.1	-37.5	-31.4	31.4	37.5	-6.1	0
	mV	0	43	-263	-220	220	263	-43	0

Table 7-11

SDTV YCbCr 75% color bars. Values are relative to the blanking level.

		White	Yellow	Cyan	Green	Magenta	Red	Blue	Black
Y	IRE	100	88.6	70.1	58.7	41.3	29.9	11.4	0
	mV	700	620	491	411	289	209	80	0
Cb	IRE	0	-50	16.9	-33.1	33.1	-16.9	50	0
	mV	0	-350	118	-232	232	-118	350	0
Cr	IRE	0	8.1	-50	-41.9	41.9	50	-8.1	0
	mV	0	57	-350	-293	293	350	-57	0

Table 7-12

SDTV YCbCr 100% color bars. Values are relative to the blanking level.

7.6.4 SDI/HDSDI IN/OUT (BNC) (LCS-42 only)

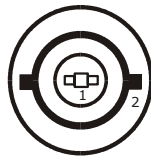

1	Signal, typ. 0.8Vpp
2	Shield
SDI/HDSDI IN	BNC input, 75 Ω terminated
SDI/HDSDI Out	BNC output, output impedance 75 Ω. Loop through of the active HDSDI input.

Table 7-13

7.6.5 DVI

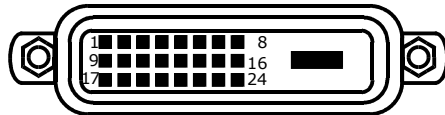

Pin	signal assignment	pin	signal assignment
1	TMDS Data 2-	13	NC
2	TMDS Data 2+	14	NC
3	TMDS Data 2 Ground	15	Ground (+5, Analog /V Sync)
4	NC	16	Hot Plug Detect (HPD)
5	NC	17	TMDS Data 0-
6	DDC Clock	18	TMDS Data 0+
7	DDC Data	19	TMDS Data 0 Ground
8	NC	20	NC
9	TMDS Data 1-	21	NC
10	TMDS Data 1+	22	TMDS Clock Ground
11	TMDS Data 1 Ground	23	TMDS Clock +
12	NC	24	TMDS Clock -

Table 7-14

7.6.6 RGB IN (D-Sub 15 pin)

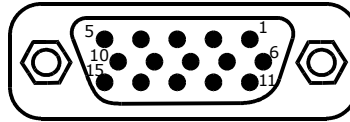

Pin	signal assignment	pin	signal assignment
1	Red video input	9	NC
2	Green video input	10	Ground
3	Blue video input	11	NC
4	NC	12	(SDA)
5	Ground	13	Horizontal sync (Composite sync)
6	Red video ground	14	Vertical sync
7	Green video ground	15	(SCL)
8	Blue video ground		

Table 7-15

7.6.7 RS232 IN

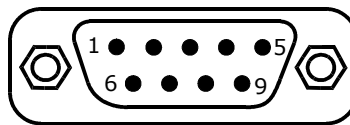

Pin	signal assignment
1	NC
2	Signal receive
3	Signal transmit
4	NC
5	Ground
6	NC
7	NC
8	NC

Table 7-16

7.6.8 RS232 OUT

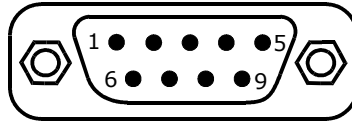

Pin	signal assignment
1	NC
2	Signal transmit
3	Signal receive
4	NC
5	Ground
6	NC
7	NC
8	NC

Table 7-17

7.7 Factory settings

Item	default	adjust range
Power switch	Off	On/Off
Brightness	80	0~100
Contrast	50	0~100
Color temp.	User	User, 3200K,5400K,6500K, 9300K
Red	255	0~255
Green	255	0~255
Blue	255	0~255
Language	English	English
Baud rate	115200	115200, 38400, 19200, 9600
Auto configuration	On	On/Off

Table 7-18

8 Technical data 47" version (LCN-47, LCS-47)

8.1 General data

characteristic	specification
Screen size	47" diagonal
Aspect ratio	16:9
active area (HxW)	1048mm x 593mm 41.26in. x 23.35in.
width x height x depth (without stand, with handle!)	1139.4mm x 684.4mm x 125mm 44.86in x 26.94in X 4.92in
weight	40.2kg 88.7lbs

Table 8-1

8.2 LCD panel

characteristic	specification
Driver element	a-Si TFT active matrix
Pixel number	(1920 x R.G.B. x 1080) pixel (HDTV)
Display colors	16.8 millions of colors
Viewing angle	176 degree vertical / 176 degree horizontal
Brightness	500 cd/m ²
Contrast ratio	1800:1
Response time (Gray to Gray)	Typ. 6.5 msec, max. 12 msec.
Interfaces	VGA (D-Sub 15 pins), DVI (DVI-D 24 pins), Composite (RCA), S-Video (Mini-DIN 4 pin), Component (Mini-DIN 8 pin), SDI/HD-SDI in/out (BNC), RS232 IN/OUT (D-Sub 9)
Dead pixel rate	Max. 8 bright pixels out of which max. 2 clusters of two bright pixels. Max. 10 dark pixels out of which max. 5 clusters of two dark pixels

Table 8-2

8.3 Electrical data

Characteristic	specification
Power supply	100VAC-240 VAC, 50/60 Hz
Power consumption operating mode	303W 1033.8 BTU/h
Power consumption Standby mode	19.9W 67.9 BTU/h

Table 8-3

8.4 Operating conditions

Characteristic	specification
Storage temperature	-20°C - +60°C -4°F - 140°F, at max. 90% RH, non-condensing
Operating ambient temperature	+5°C - +40°C 41°F - 104°F, at max. 90% RH, non-condensing

Table 8-4

8.5 CCFL (Cold Cathode Fluorescent Lamp) characteristics (ambient temperature (25 ±2)°C)

Characteristic	Typ. value
Lamp voltage	1750 VRMS
Lamp current	6 mARMS
Lamp starting voltage	2350 VRMS (0°C), 2150 VRMS (25°C)
Lamp life time	50,000hrs *)
Operating frequency	40-70 KHz

Table 8-5

The life time of a lamp is defined as when the brightness is larger than 50% of its original value and the effective discharge length is longer than 80% of its original length.

8.6 Interfaces

8.6.1 Video IN (Composite Video)

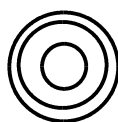

Item	specification
Signal level	1.0Vpp
Connector type	RCA Jack
Termination	75Ω

Table 8-6

8.6.2 S-Video



Item	specification
1,2	Ground
3	Y
4	C
Luminance level	1.0 Vpp
Color level	0.286 Vpp
Connector type	Mini Din 4pin
Termination	75Ω

Table 8-7

8.6.3 Component Video



Item	specification	Item	specification
1	GND	5	GND
2	CB	6	CR
3	GND	7	not connected
4	Y	8	not connected
Connector type		Mini Din 8pin	
Termination		75Ω	

Table 8-8

		White	Yellow	Cyan	Green	Magenta	Red	Blue	Black
Y	IRE	75	69.5	59.1	53.6	21.4	15.9	5.4	0
	mV	525	487	413	375	150	112	38	0
Pb	IRE	0	-37.5	8.6	-28.9	28.9	-8.6	37.5	0
	mV	0	-263	60	-202	202	-60	263	0
Pr	IRE	0	3.4	-37.5	-34.1	34.1	37.5	-3.4	0
	mV	0	24	-263	-238	238	263	-24	0

Table 8-9

HDTV YPbPr 75% color bars. Values are relative to the blanking level.

		White	Yellow	Cyan	Green	Magenta	Red	Blue	Black
Y	IRE	100	92.8	78.7	71.5	28.5	21.3	7.2	0
	mV	700	649	551	501	199	149	51	0
Pb	IRE	0	-50	11.5	-38.5	38.5	-11.5	50	0
	mV	0	-350	80	-270	270	-80	350	0
Pr	IRE	0	4.6	-50	-45.4	45.4	50	-4.6	0
	mV	0	32	-350	-318	318	350	-32	0

Table 8-10

HDTV YPbPr 100% color bars. Values are relative to the blanking level.

		White	Yellow	Cyan	Green	Magenta	Red	Blue	Black
Y	IRE	75	66.5	52.6	44.0	31.0	22.4	8.6	0
	mV	525	465	368	308	217	157	60	0
Cb	IRE	0	-37.5	12.7	-24.8	24.8	-12.7	37.5	0
	mV	0	-263	89	-174	174	-89	263	0
Cr	IRE	0	6.1	-37.5	-31.4	31.4	37.5	-6.1	0
	mV	0	43	-263	-220	220	263	-43	0

Table 8-11

SDTV YCbCr 75% color bars. Values are relative to the blanking level.

		White	Yellow	Cyan	Green	Magenta	Red	Blue	Black
Y	IRE	100	88.6	70.1	58.7	41.3	29.9	11.4	0
	mV	700	620	491	411	289	209	80	0
Cb	IRE	0	-50	16.9	-33.1	33.1	-16.9	50	0
	mV	0	-350	118	-232	232	-118	350	0
Cr	IRE	0	8.1	-50	-41.9	41.9	50	-8.1	0
	mV	0	57	-350	-293	293	350	-57	0

Table 8-12

SDTV YCbCr 100% color bars. Values are relative to the blanking level.

8.6.4 SDI/HDSDI IN/OUT (BNC)



1	Signal, typ. 0.8Vpp
2	Shield
SDI/HDSDI IN	BNC input, 75 Ω terminated
SDI/HDSDI Out	BNC output, output impedance 75 Ω . Loop through of the active HDSDI input.

Table 8-13

8.6.5 DVI

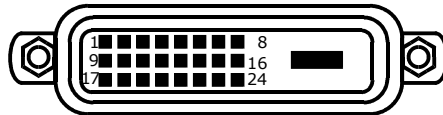

Pin	signal assignment	pin	signal assignment
1	TMDS Data 2-	13	NC
2	TMDS Data 2+	14	NC
3	TMDS Data 2 Ground	15	Ground (+5, Analog /V Sync)
4	NC	16	Hot Plug Detect (HPD)
5	NC	17	TMDS Data 0-
6	DDC Clock	18	TMDS Data 0+
7	DDC Data	19	TMDS Data 0 Ground
8	NC	20	NC
9	TMDS Data 1-	21	NC
10	TMDS Data 1+	22	TMDS Clock Ground
11	TMDS Data 1 Ground	23	TMDS Clock +
12	NC	24	TMDS Clock -

Table 8-14

8.6.6 RGB IN (D-Sub 15 pin)

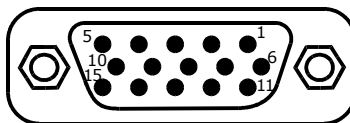

Pin	signal assignment	pin	signal assignment
1	Red video input	9	NC
2	Green video input	10	Ground
3	Blue video input	11	NC
4	NC	12	(SDA)
5	Ground	13	Horizontal sync (Composite sync)
6	Red video ground	14	Vertical sync
7	Green video ground	15	(SCL)
8	Blue video ground		

Table 8-15

8.6.7 RS232 IN

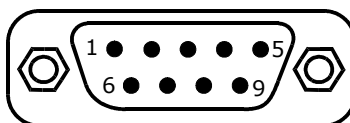

Pin	signal assignment
1	NC
2	Signal receive
3	Signal transmit
4	NC
5	Ground
6	NC
7	NC
8	NC

Table 8-16

8.6.8 RS232 OUT

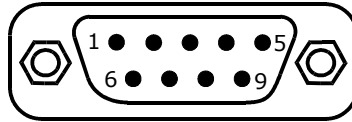

Pin	signal assignment
1	NC
2	Signal transmit
3	Signal receive
4	NC
5	Ground
6	NC
7	NC
8	NC

Table 8-17

8.7 Factory setting

Item	default	adjust range
Power switch	Off	On/Off
Brightness	80	0~100
Contrast	50	0~100
Color temp.	User	User, 3200K,5400K,6500K, 9300K
Red	255	0~255
Green	255	0~255
Blue	255	0~255
Language	English	English
Baud rate	115200	115200, 38400, 19200, 9600
Auto configuration	On	On/Off

Table 8-18

9 Compliant timing

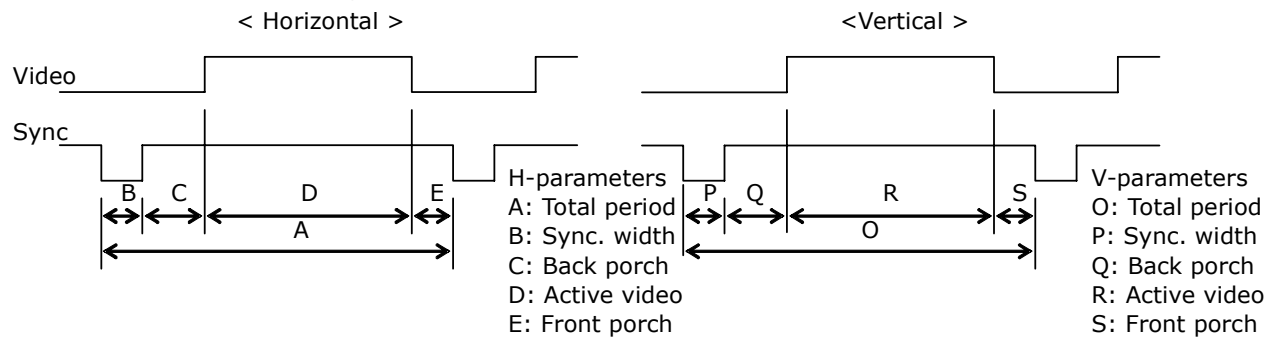

Graphics Mode	fH (kHz)	fV (Hz)	Dot clock (MHz)	Sync polarity		Horizontal (dot)					Vertical (line)					Analog (VGA)	Digital (DVI-D)	
				H	V	A	B	C	D	E	O	P	Q	R	S			
VESA	VGA 640x480	37.861	72.809	31.500	N	N	832	40	120	640	32	520	3	20	480	17	OK	OK
		37.500	75.000	31.500	N	N	840	64	120	640	16	500	3	16	480	1	OK	OK
		43.269	85.010	36.000	N	N	832	56	80	640	56	509	3	25	480	1	OK	OK
	SVGA 800x600	35.156	56.250	36.000	P	P	1024	72	128	800	24	625	2	22	600	1	OK	OK
		37.879	60.317	40.000	P	P	1056	128	88	800	40	628	4	23	600	1	OK	OK
		48.077	72.188	50.000	P	P	1040	120	64	800	56	666	6	23	600	37	OK	OK
		46.875	75.000	49.500	P	P	1056	80	160	800	16	625	3	21	600	1	OK	OK
		53.674	85.06	56.250	P	P	1048	64	152	800	32	631	3	27	600	1	OK	OK
	XGA 1024x768	48.363	60.004	65.000	N	N	1344	136	160	1024	24	806	6	29	768	3	OK	OK
		56.476	70.069	75.000	N	N	1328	136	144	1024	24	806	6	29	768	3	OK	OK
		60.023	75.029	78.750	P	P	1312	96	176	1024	16	800	3	28	768	1	OK	OK
		68.677	85.00	94.500	N	N	1376	96	208	1024	48	808	3	36	768	1	OK	OK
	WXGA 1360x768	47.712	59.94	84.737	N	N	1776	152	176	1360	88	796	3	24	768	1	OK	OK
	SXGA 1152x864	67.500	75.000	108.000	P	P	1600	128	256	1152	64	900	3	32	864	1	OK	OK
	SXGA 1280x960	60.000	60.00	108.000	N	N	1800	112	312	1280	96	1000	3	36	960	1	OK	OK
		85.938	85.00	148.501	N	N	1728	160	224	1280	64	1011	3	47	960	1	OK	OK
	SXGA 1280x1024	63.981	60.020	108.000	P	P	1688	112	248	1280	48	1066	3	38	1024	1	OK	OK
		79.976	75.025	135.000	P	P	1688	144	248	1280	16	1066	3	38	1024	1	OK	OK
		91.146	85.02	157.500	P	P	1728	160	224	1280	64	1072	3	44	1024	1	OK	OK
	SXGA+ 1400x1050	65.316	59.978	121.749	N	N	1864	144	232	1400	88	1089	4	32	1050	3	OK	OK
82.278		74.866	156.000	N	N	1896	144	248	1400	104	1099	4	42	1050	3	OK	OK	
UXGA 1600x1200	75.00	60.00	162.000	N	N	2160	192	304	1600	64	1250	3	46	1200	1	OK	OK	

Video Mode		fH (kHz)	fV (Hz)	Dot clock (MHz)	Sync polarity		Horizontal (dot)					Vertical (line)					Analog (VGA)	Digital (DVI-D)
					H	V	A			D	E	O	P	Q	R	S		
SMPTE 296M HDTV	720p 1280x780	37.500	50	74.25	N	N	1980	40	220	1280	440	750	5	20	720	5	OK	OK
		45.000	60	74.250	P	P	1650	40	220	1280	110	750	5	20	720	5	OK	OK
		44.995	59.94	74.176	P	P	1650	40	220	1280	110	750	5	20	720	5	OK	OK
SMPTE 274M HDTV	1080p 1920x1080	56.250	50.00	148.500	P	P	2640	44	148	1920	528	1125	5	36	1080	4	OK	OK
		67.433	59.94	148.352	P	P	2200	44	148	1920	88	1125	5	36	1080	4	OK	OK
		67.500	60.00	148.500	P	P	2200	44	148	1920	88	1125	5	36	1080	4	OK	OK
	1080i 1920x1080	28.13	50.00	74.25	P	P	2640	44	148	1920	528	1125	5	38	1080	4	OK	OK
		33.716	59.94	74.176	P	P	2200	44	148	1920	88	1125	5	38	1080	4	OK	OK
		33.750	60	74.25	P	P	2200	44	148	1920	88	1125	5	38	1080	4	OK	OK
NTSC	NTSC 358-443	15.734	59.94	16.521	Composite, S-video and component video inputs accept only standard 480i NTSC and 576i PAL-SECAM video.													
PAL	PAL SECAM	15.625	50.00	16.406	DVI and VGA inputs accepts progressive 480p and 576p video.													

9.1 SDI input signals

The Serial Digital Interface (SDI) input complies with the standard SMPTE 259M.

The input board accepts the following SDI input formats and types (table 1):

Resolution	Signal type
720x480	NTSC
720x576	PAL

9.2 HD-SDI input signals

The HD-SDI input complies with the standard SMPTE 292M.

The HD-SDI input supports the following resolutions (table 2).

Resolution	Samples per total line	Total lines per frame	Samples per active line	Active lines per frame	scanning format	frame rate [Hz]
1280x720	1650	750	1280	720	1:1 p	60
1280x720	1650	750	1280	720	1:1 p	60/ <i>M</i>
1280x720	1980	750	1280	720	1:1 p	50
1920x1080	2200	1125	1920	1080	2:1 i	30
1920x1080	2200	1125	1920	1080	2:1 i	30/ <i>M</i>
1920x1080	2640	1125	1920	1080	2:1 i	25
1920x1080	2200	1125	1920	1080	1:1 prog	30
1920x1080	2200	1125	1920	1080	1:1 prog	30/ <i>M</i>
1920x1080	2640	1125	1920	1080	1:1 prog	25
1920x1080	2750	1125	1920	1080	1:1 prog	24

HD-SDI-Resolutions (M=1.001, p=progressive, i=interlaced) at data rate 1.485 or 1.485/1.001 Gb/s.

10 Troubleshooting

When faults occur which are not described below please contact Barco.

10.1 Faults

Faults	cause/steps
No picture	<p>Make sure that the power cord is plugged into the wall outlet.</p> <p>Make sure that the power switch on the rear of the monitor is switched on!</p> <p>Make sure that the monitor is not in standby (check the LED indicator: if it shows orange, the monitor is in standby)</p> <p>Check if the signal cables are properly connected to the monitor and to the signal source</p> <p>Check if the input setting is correct (VGA, DVI, Composite, S-Video, Component, HD-SDI)</p> <p>Check if the signal is suitable.</p>
The monitor can not be controlled via the IR RCU	<p>Make sure that the batteries are inserted correctly (matching the + and – marks of the battery compartment)</p> <p>Replace the batteries.</p> <p>Point the front of the RCU directly to the sensor on the screen.</p> <p>The remote control unit will not function properly if strong light strikes the sensor window or if there are obstacles between the remote control unit and the IR sensor.</p>
The picture color is pale, or not clear	<p>Check the Color setting</p> <p>If you are using YUV terminals, make sure that the cables are correctly connected!</p>
The picture is green or purple when VGA signal is connected	Press F4 on the remote control.
Picture vibrates when genlock is selected on the Barco Transform H/A controller	Restart the monitor to let it resync.
Picture vibrates when interlaced video signal is brought to the DVI or VGA input.	Restart the monitor to let it resync.
The monitor doesn't work with the analog output of the Barco Transform H/A controllers	It is not supposed to. Use the digital output and DVI input to the monitor.
PC/graphical card doesn't work on the VGA input	Use the digital output (DVI) of your graphical card or docking station.
The monitor says 'no signal' or 'no cable' when a DVI or VGA signal is attached.	This may happen if a video input is used before switching off. Keep pressing F1 on the remote control until the right input is selected. If this doesn't help, check the table of timings to make sure the input signal is supported.
The VGA image is not scaled properly.	Press the button on the remote control to autoadjust.

Table 10-1

10.2 Contact

Feel free to contact us if you have any further questions!

- **Barco Control Rooms GmbH**
An der Rossweid 5 • D-76229 Karlsruhe • Germany
Phone (49) (721) 6201-163 • Fax (49) (721) 6201-298
E-mail support.de.bcd@barco.com, Web www.barcocontrolrooms.de
- **BARCO N.V.**
President Kennedypark 35 • B-8500 Kortrijk • Belgium
Phone (32) (56) 36-8282 • Fax (32) (56) 36-82 51
E-mail support.controlrooms@barco.com, Web www.barcocontrolrooms.com
- **BARCO N.V. Media**
Noordlaan 5 • B-8520 Kuurne • Belgium
Phone (32) (56) 36-8970 • Fax (32) (56) 36-8386
E-mail media@barco.com, Web www.barco.com

11 Compliance statement

11.1 FCC Compliance statement

This equipment has been tested and found to comply with the limits for a Class A digital device, pursuant to part 15 of the FCC Rules. These limits are designed to provide reasonable protection against harmful interference when the equipment is operated in a commercial environment. This equipment generates, uses, and can radiate radio frequency energy and, if not installed and used in accordance with the instruction manual, may cause harmful interference to radio communications. Operation of this equipment in a residential area is likely to cause harmful interference in which case the user will be required to correct the interference at his own expense.



This is a class A product. In a domestic environment this product may cause radio interference in which case the user may be required to take adequate measures.

This device complies with Part 15 of the FCC Rules. Operation is subject to the following two conditions :

- (1) this device may not cause harmful interference, and
- (2) this device must accept any interference received, including interference that may cause undesired operation

12 Accessories

The monitor can be equipped with a table stand, or mounted to the wall or the ceiling. The following chapter describes assembling and installation of the accessories.

12.1 Required tools

- Screwdriver for recessed head screws (screw size M8)

Wall mount and ceiling mount:

- Wrench 10mm, 17mm, 19mm
- Allen wrench size 2.5 to adjust the tilt angle of the long/short ceiling mount
- Drilling machine to drill the holes into concrete
- 4 fixation screws per wall mount / ceiling mount
- 1 additional (center) fixation screw for the tiltable wall mount
- 4 (5) dowels (concrete)



The manufacturer of the accessories gives the following recommendation:

Specification of screws for wood: DIN 571 M8x80 4.6

Specification of screws for concrete DIN 16168 M8x75

12.2 Table stand



The table stand allows adjusting the monitor in height.

**For the 42" version, the lower edge can be set between 14mm and 204mm;
for the 47" versions, the lower edge can be set between 14mm and 135mm.**

12.2.1 Scope of delivery

The table stand comes fully assembled.

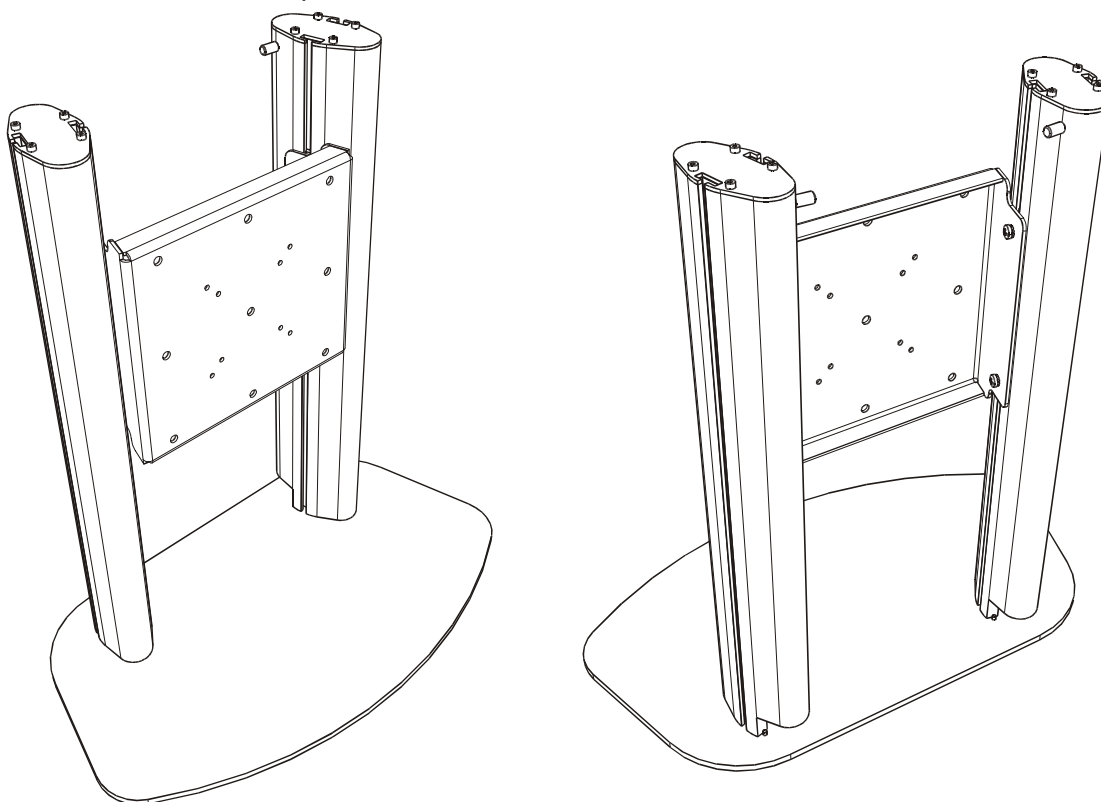

12.2.2 Installation

The monitors feature on their rear side 2 parallel arrangements of 4 threads each. These threads comply with the VESA standards, their horizontal and vertical distance is 200mm. They are equipped with the respective screws (M8x15).

These screws are used to attach the table stand!

- Lay the monitor upside down on a clean(!) surface, bottom edge flush with e.g. edge of the table.



Soil or particles laying on the surface may irretrievably damage the screen of the monitor!

- Take a screwdriver for recessed head screws (screw size M8).
- Remove the 4 center screws and washers on the rear side of the monitor.

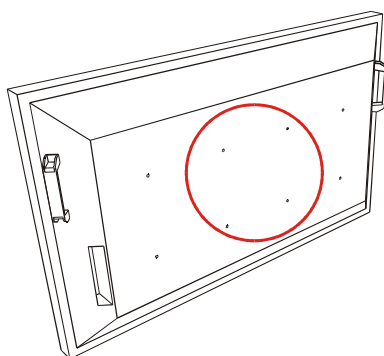

- Take the table stand and attach its mounting plate to the rear of the monitor using the previously removed screws and washers.

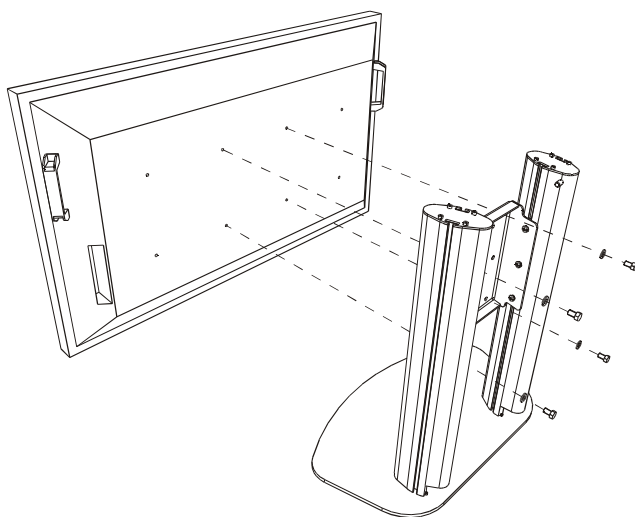

Mind the correct orientation of the table stand!

- When the screws are fastened tightly, put up the monitor

12.2.3 Dimensions

12.2.3.1 Dimensions of the 42" version

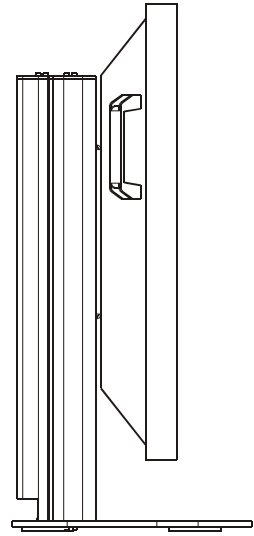
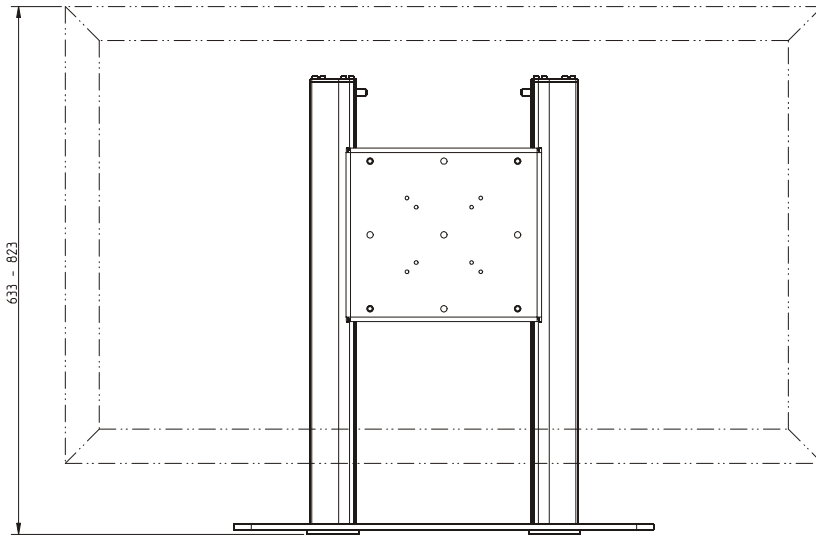

12.2.3.2 Dimension of the 47" version

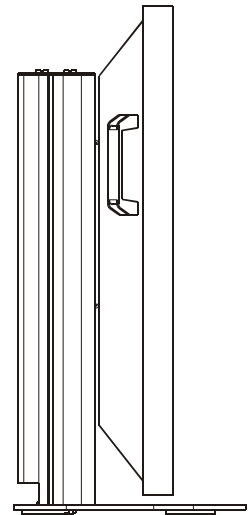
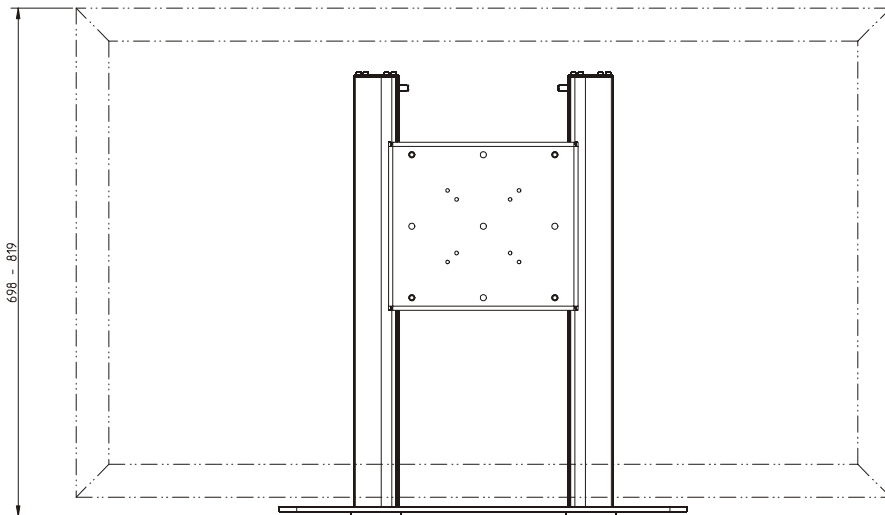

12.2.4 Height adjustment

The monitor can be adjusted in height by sliding the mounting plate up or down, respectively.



**For adjusting the table stand in height,
first uninstall the monitor!!**

**Never loosen the screws for sliding the plate when the monitor is still attached to the
table stand! Otherwise the monitor will crash on the table!!**

- Uninstall the monitor!
- Remove the 2 fixation screws of the plate to the vertical bar at each side.
- Re-position the monitor.
- Re-attach the screws.
- Install the table stand to the monitor.

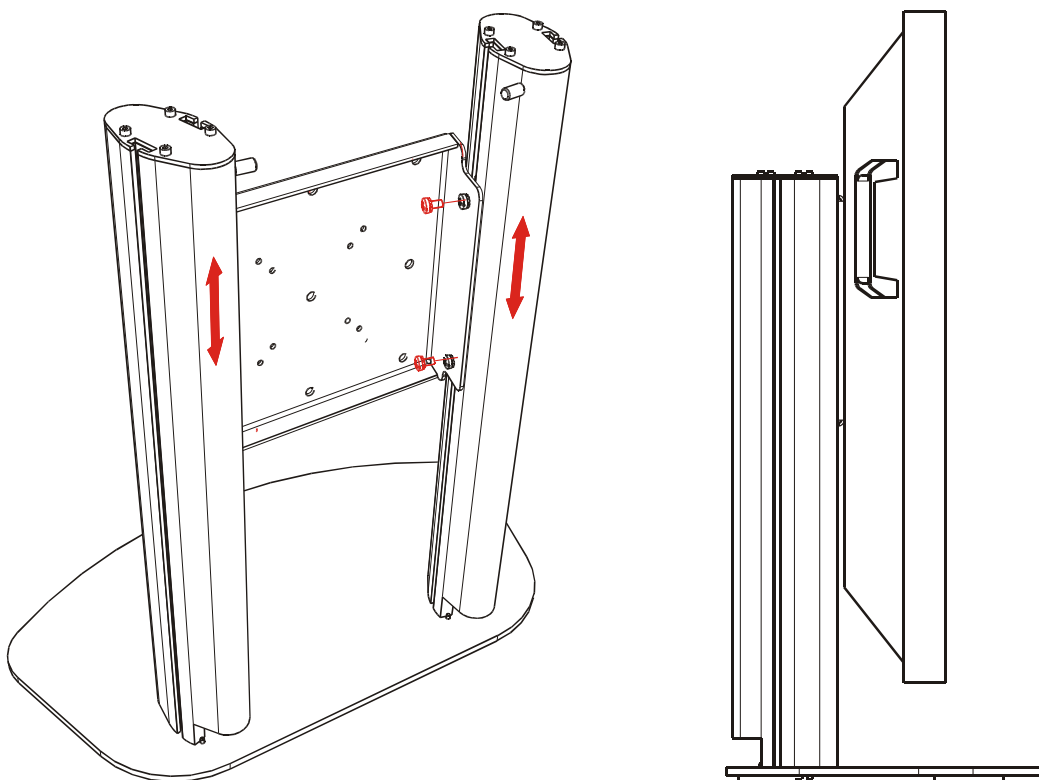

12.3 Screen bracket (adapter plate)



The installation of the screen bracket is mandatory for fixation of the wall mount, and the ceiling mount..

12.3.1 Scope of delivery

The screen bracket is one component; for its installation the screws on the rear side of the monitor are used.

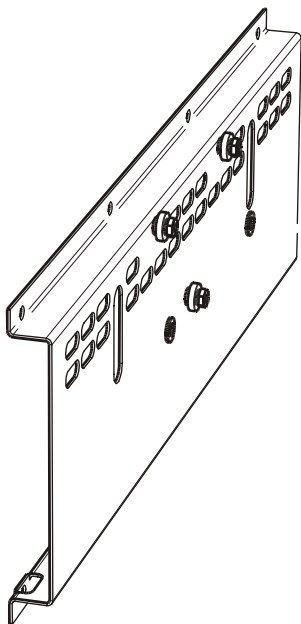

12.3.2 Installation

The monitors feature on their rear side 2 parallel arrangements of 4 threads each. The threads comply with the VESA standards, their horizontal and vertical distance is 200mm. These threads are equipped with the respective screws (M8x15).

These screws are used to attach the screen bracket!

To install the screen bracket, proceed as follows:

- Lay the monitor upside down on a clean(!) surface.
- Take a screwdriver for recessed head screws (screw size M8).
- Remove the 8 screws and washers on the rear side of the monitor.
- Take the screen bracket, and fix it with the 8 screws and washers as shown below.

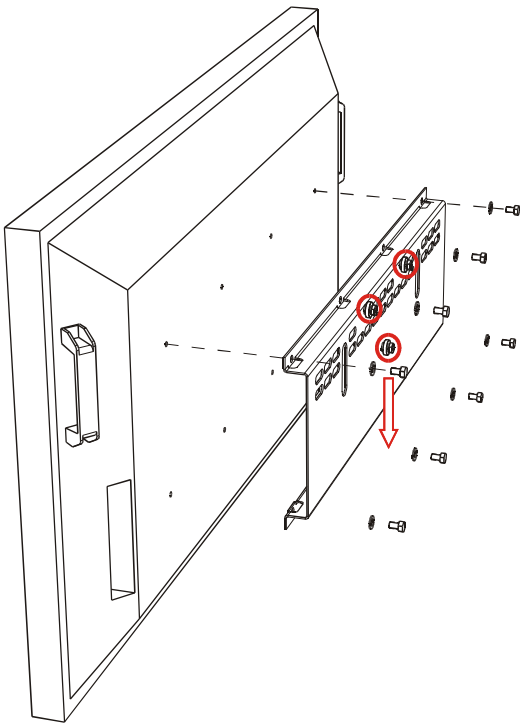

The screen bracket is equipped with 3 knurled bolts which are later slid into the fixation plate of the wall mount / ceiling mount. These bolts are arranged in a triangle. Make sure that the screen bracket is fixed with the top of the triangle showing to the bottom of the monitor!

12.4 Fixed wall mount



First mount the screen bracket to the monitor, cf. [Screen bracket \(adapter plate\)](#)

Use the fixed wall mount to attach the monitor to the wall.

The drawings show the fixation facility itself and a monitor which is equipped with a fixed wall mount.

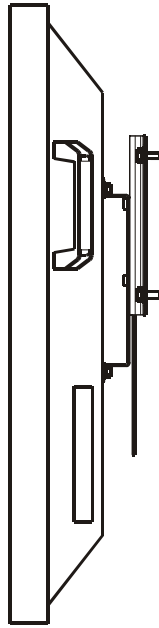
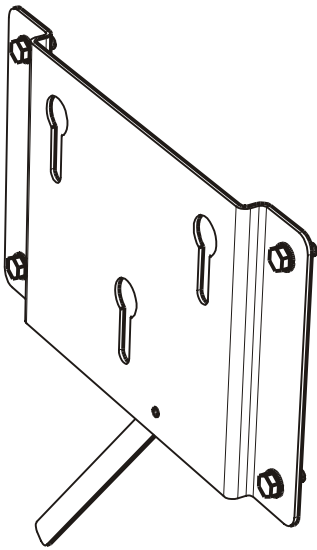

12.4.1 Scope of delivery

The fixed wall mount comes in one piece. The 4 screws to attach it to the wall have to be provided on site!

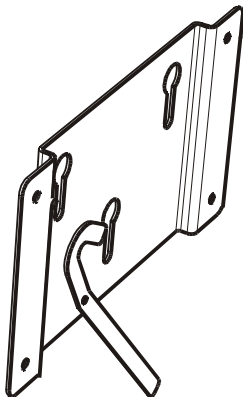

12.4.2 Installation

The wall mount bracket is attached to the wall by means of 4 screws M8 (for specification of the screws, cf. [Required tools](#)). It is the same bracket for 42" and 47".



For drilling the holes in the wall, it is recommended to use a jig – take a sheet of paper (A3) and copy the distances given in the drawing below.

- Drill 4 holes, 10mm, to the wall in the given distances!

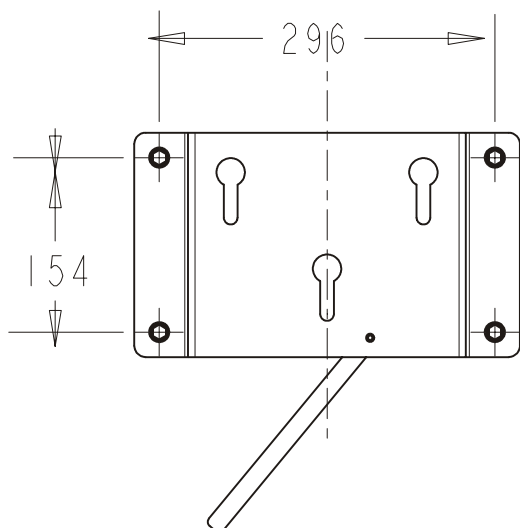

- Use 4 screws M8 and fix the wall mount to the wall.
- Slid in the knurled bolts of the screen bracket into the keyholes of the wall mount and lock them by turning the lock bar.

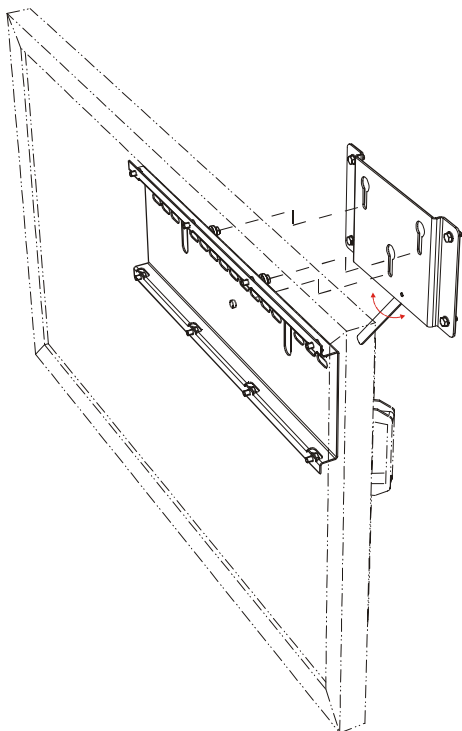

12.4.3 Dimensions

The following pictures give an overview about the measurements and dimensions of the 42" version and the 47".

12.4.3.1 Dimensions of the 42" version:

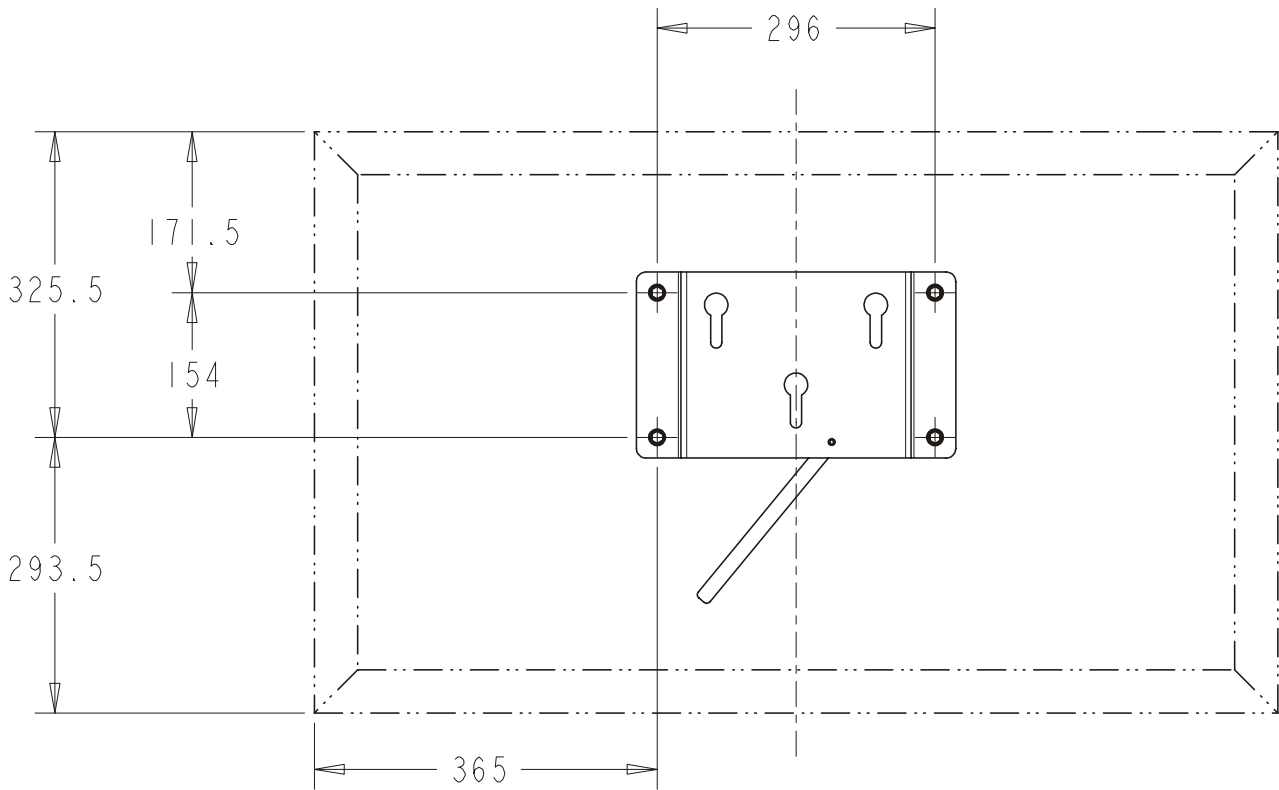

12.4.3.2 Dimension of the 47" version:

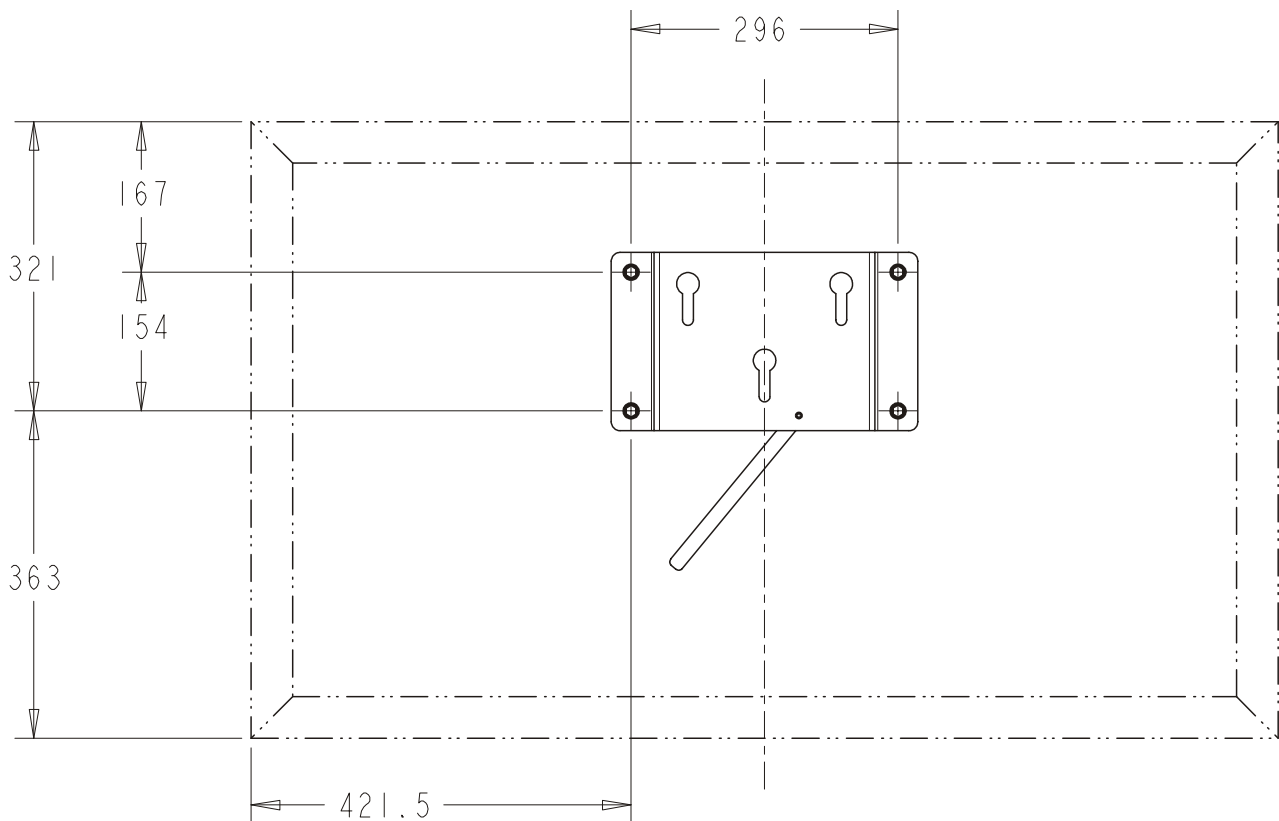

12.4.4 Wall pattern

In case of a "monitor wall", the arrangement of the holes in the wall can be taken from the following pictures:

12.4.4.1 Wall pattern 42"

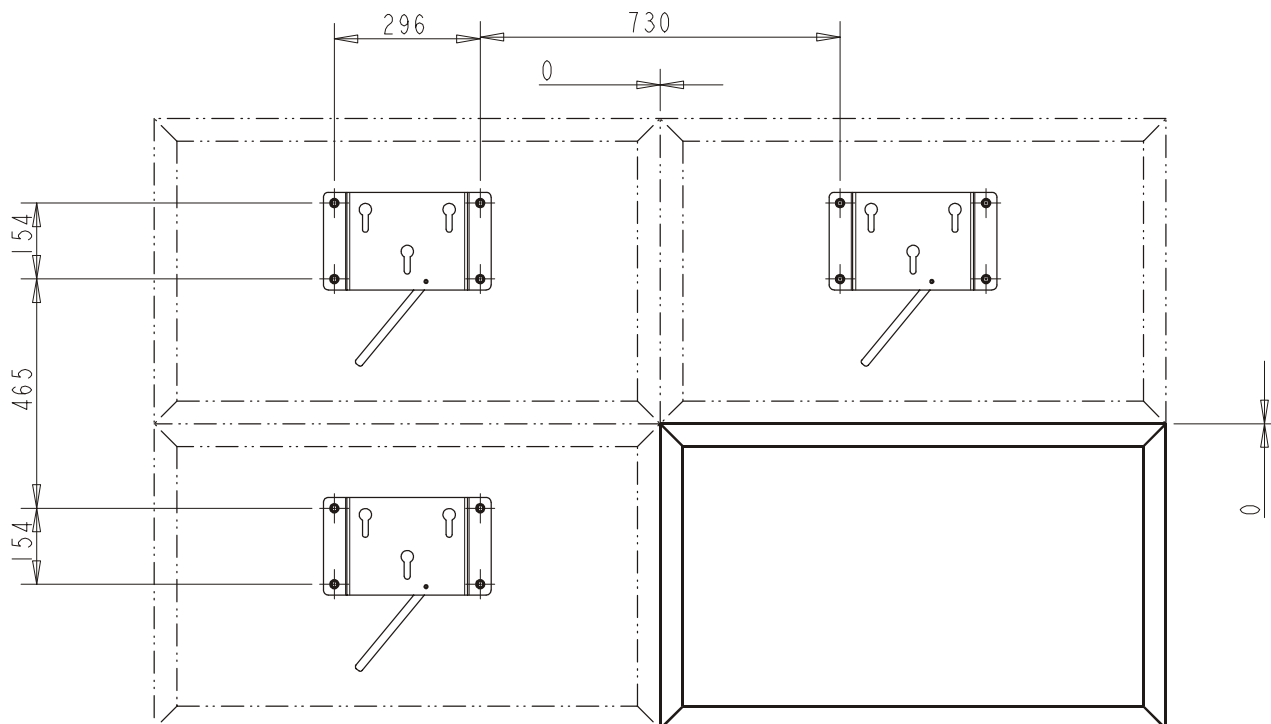

12.4.4.2 Wall pattern 47"

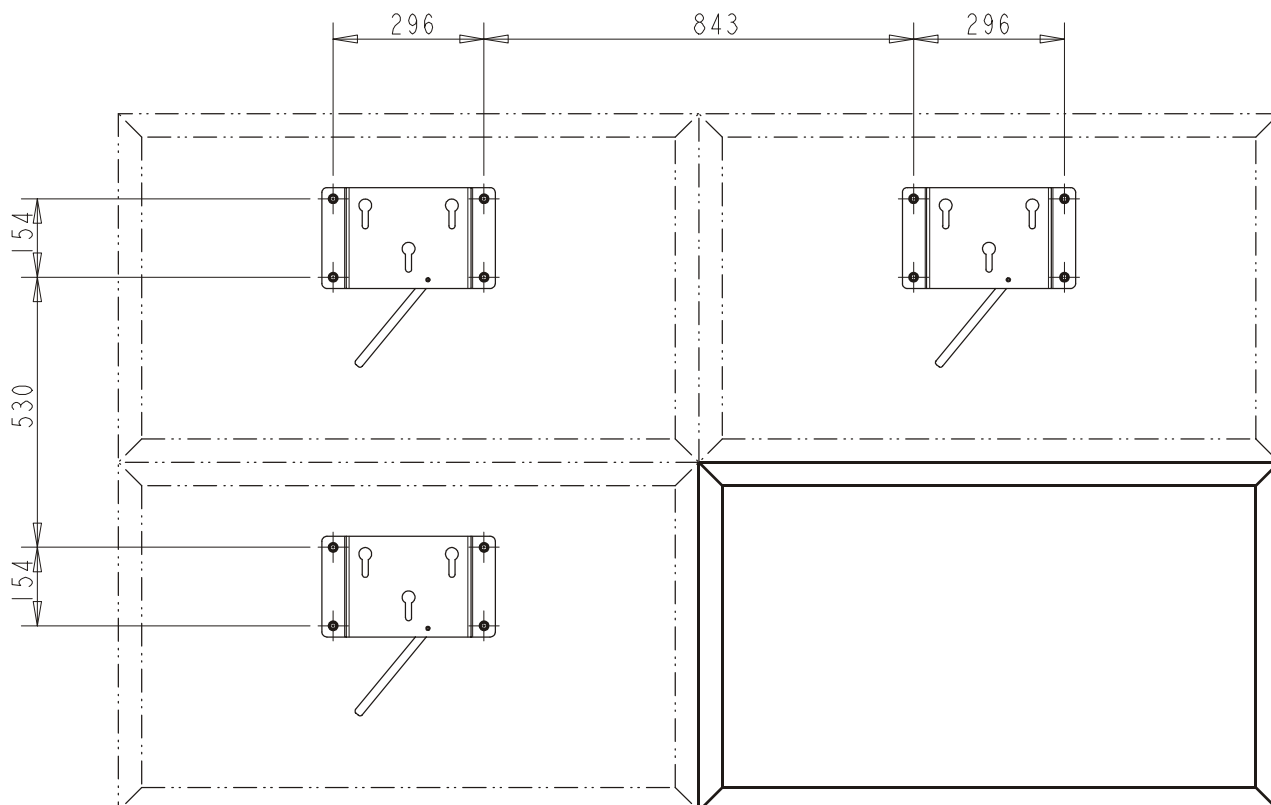

12.5 Tiltable wall mount



First mount the screen bracket to the monitor, cf. [Screen bracket \(adapter plate\)](#)

The tiltable wall mount fixes the monitor to the wall and allows setting its position in 5 steps between zero and 20 degrees. The drawings show the tiltable wall mount at max. and min. tilt angle.

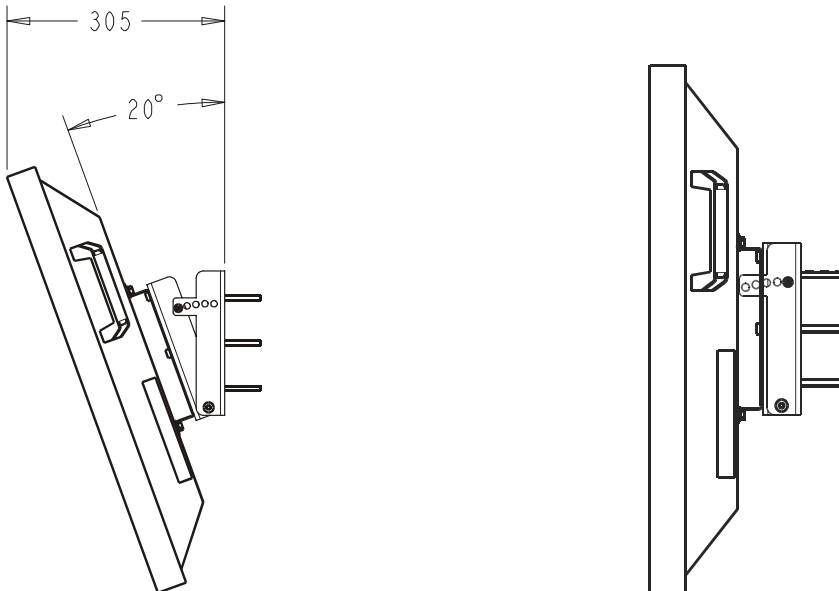

12.5.1 Scope of delivery

The tiltable wall mount comes fully assembled. It comprises a front plate and a rear plate. The rear plate will be attached to the wall, the front plate to the screen bracket of the monitor. The angle between the rear plate and the front plate can be set in 5 steps from zero to 20 degrees (angle between wall and monitor display).

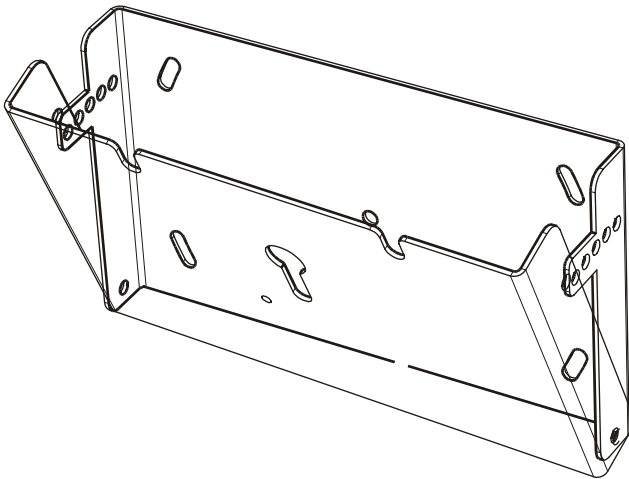

12.5.2 Installation

The rear plate of the tiltable wall mount bracket is attached to the wall by means of 5 screws M8 (for specification of the screws, cf. [Required tools](#)). It is the same bracket for 42" and 47".



For drilling the holes in the wall, it is recommended to use a jig – take a sheet of paper (A3) and copy the distances given in the drawing below.

- Drill 5 holes, 10mm, to the wall in the given distances!

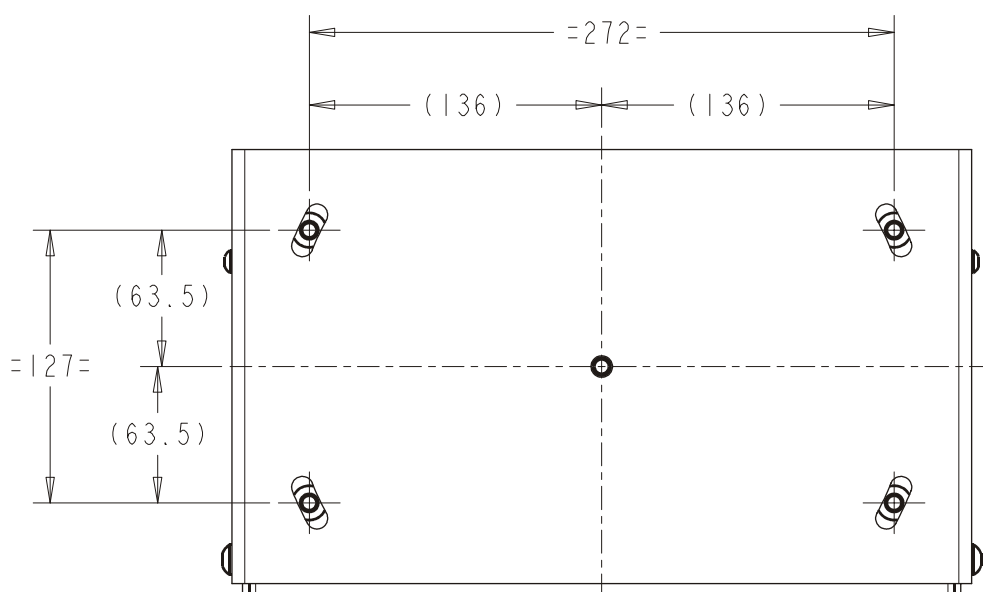

- Slid in the knurled bolts of the screen bracket into the keyholes of the wall mount and lock them by turning the lock bar.

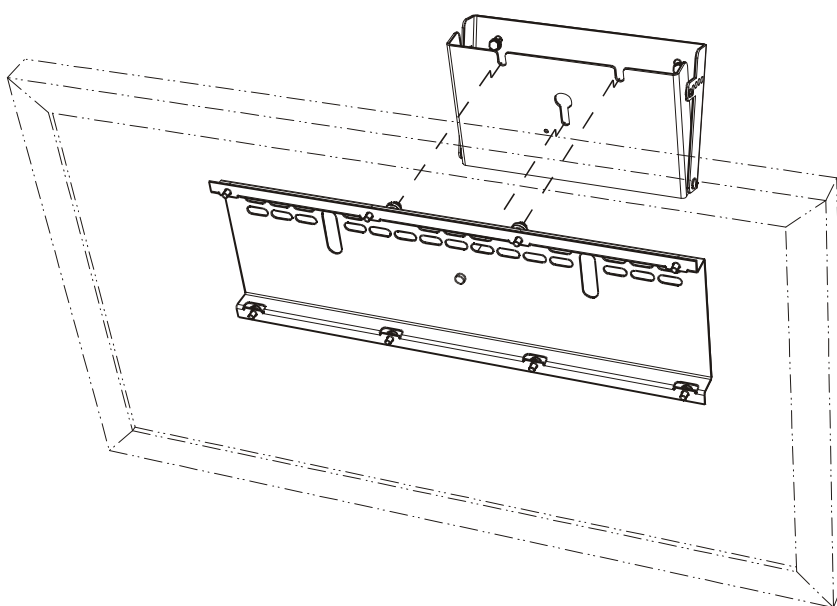

12.5.3 Dimensions

The following pictures give an overview about the measurements and dimensions of the 42" version and the 47".

12.5.3.1 Dimensions of the 42" version:

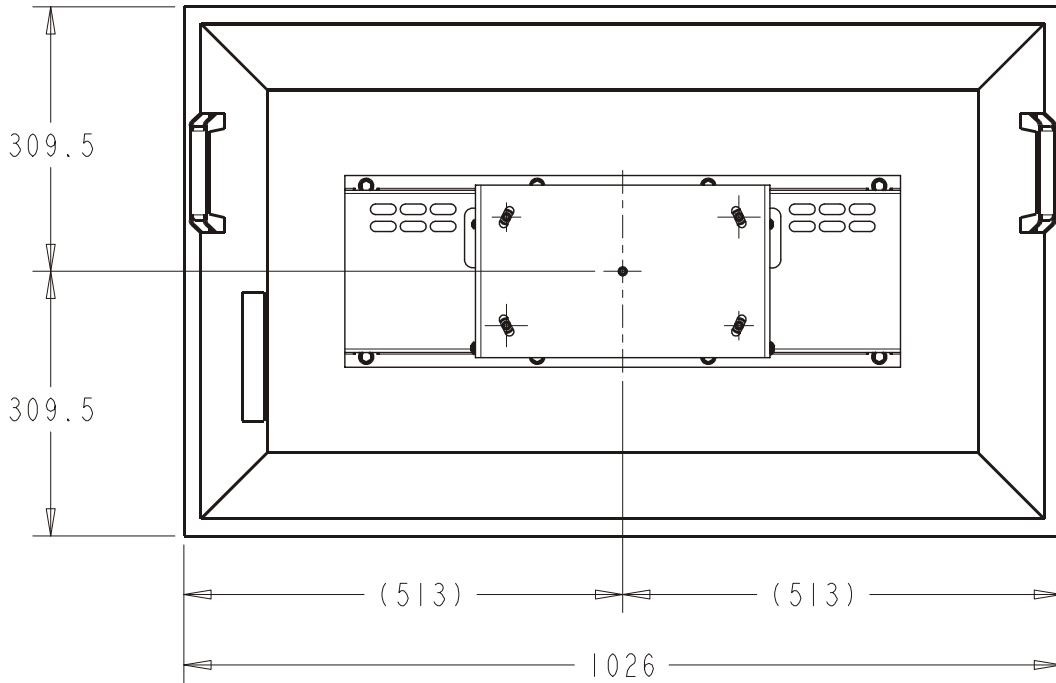

12.5.3.2 Dimensions of the 47" version:

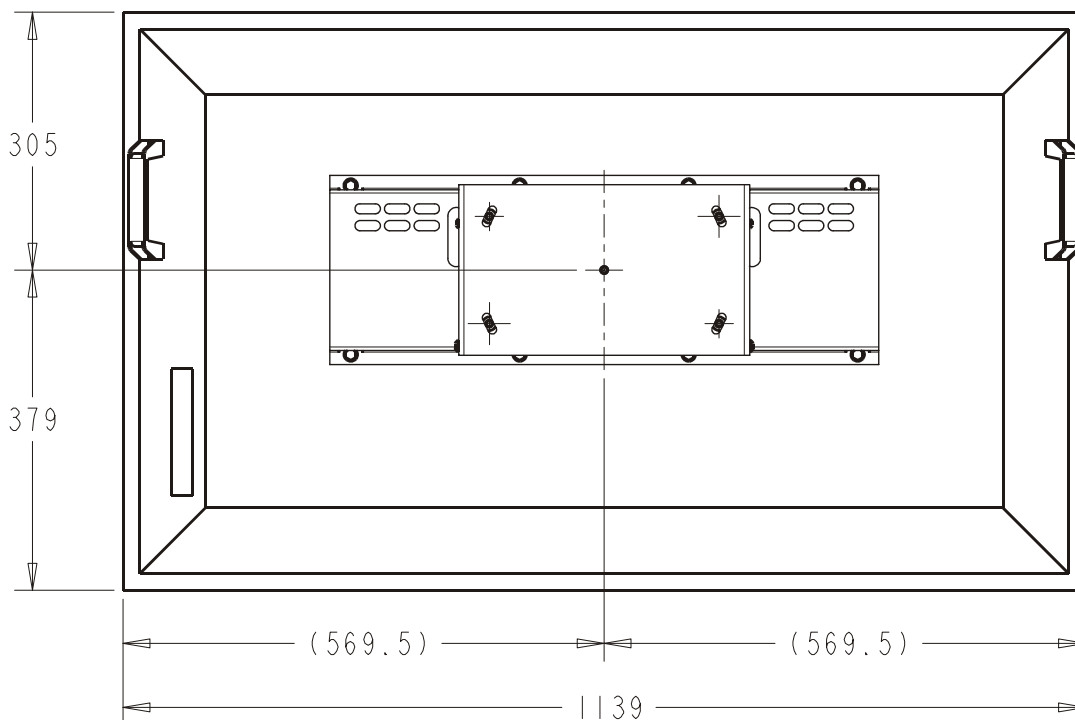

12.5.4 Tilting

To tilt the monitor, the two top screws connecting the rear plate and the front plate have to be removed.



**If you want to change the tilt angle of the monitor,
first uninstall the monitor!!**

**Never loosen the screws for setting the tilt angle when the monitor is still attached to the
tiltable wall mount!**

- Uninstall the monitor!
- Use the included allen wrench 4mm to loosen the left and the right top screws.
- Tilt the front plate to the desired degree.
- Reattach the screws.
- Re-install the monitor.

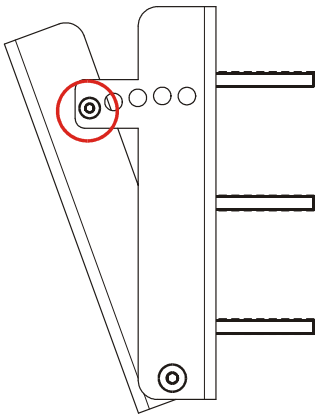

**For security reasons, the two top screws to adjust the tilting angle are applied with a
center pin and thus require a special tool. Therefore the allen wrench 4mm is included
which feature a center hole for the pin.**

12.6 Short ceiling mount



First mount the screen bracket to the monitor, cf. [Screen bracket \(adapter plate\)](#)

The short ceiling mount fixes the monitor to the ceiling and allows setting the lower screen edge to a distance of the ceiling between 706.5mm and 885.5mm for the 42" versions, and between 776mm and 955mm for the 47" versions, respectively.

The monitors can be tilted by 20 degrees thanks to the ball point on the ceiling fixation plate.

The drawings show the fixation facility itself and a monitor equipped with the short ceiling mount.

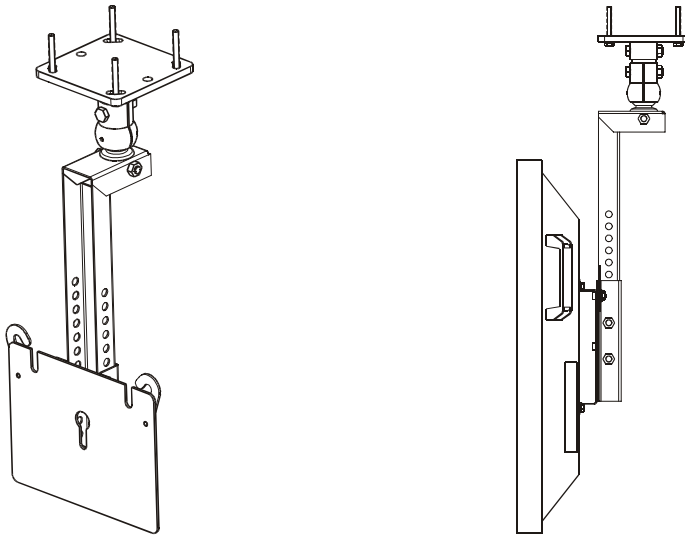

12.6.1 Scope of delivery

The short ceiling mount comprises 3 parts:

- The base plate with the ball point connection to the adjustable bar. This base plate will be mounted on the ceiling.
- The adjustable bar.
- The adapter plate to attach to the screen bracket of the monitor with two hooks to lock the knurled bolts.

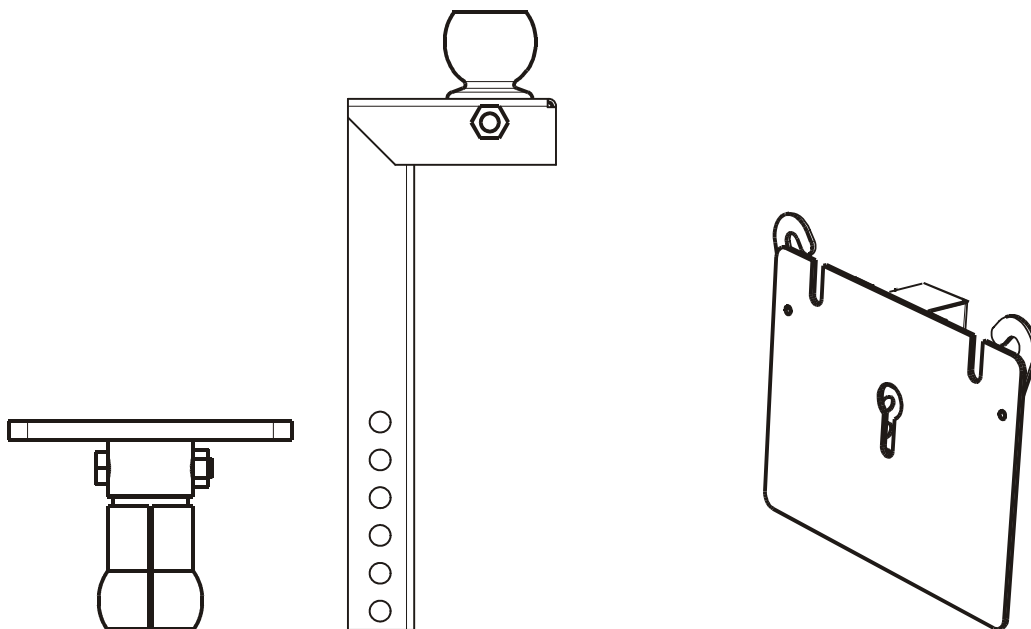

The screws to assemble the short ceiling bar are included. You will need a wrench 17mm.

The screws to fix the base plate to the ceiling have to be provided on site, cf. [Required tools](#).

12.6.2 Installation

The short ceiling mount is attached to the ceiling by means of 4 screws M8 (for specification of the screws, cf. [Required tools.](#)). It is the same bracket for 42" and 47".



For drilling the holes in the ceiling, it is recommended to use a jig – take a sheet of paper (A4) and copy the distances given in the drawing below.

- Drill 4 holes, 10mm, to the ceiling in the given distances!

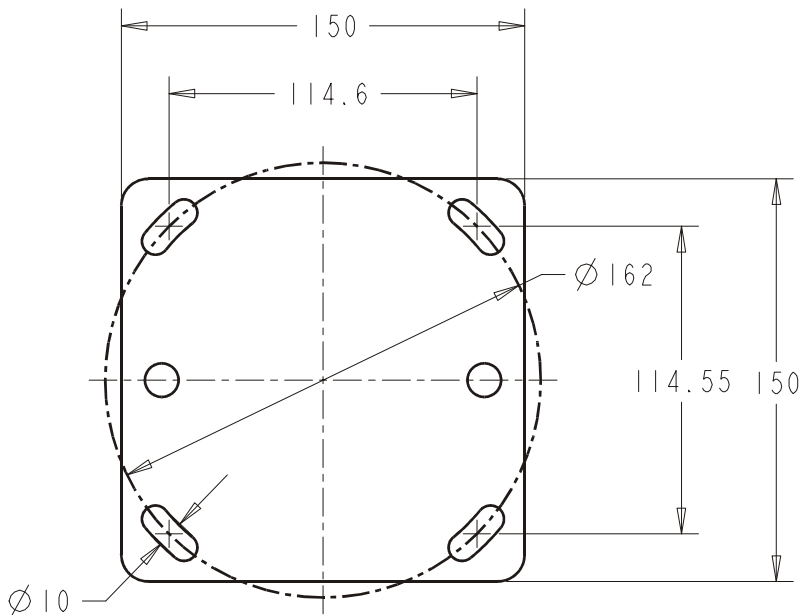

- Attach the ceiling mounting plate.
- Attach the adjustable bar to the ball joint of the ceiling mounting plate by using one of the included screws M10x60. Secure the screw with the nut and attach the black plastic cap. Also attach a black plastic cap to the already installed parallel screw on the ceiling mounting plate.
- Slide in the adjustable bar into the monitor mounting plate of the short ceiling mount. Fix its position by one of the included screws M10x60. Secure the screw with the nut and attach the black plastic cap.

- The knurled bolts of the screen bracket are slid into the keyholes of the wall mount and locked by turning the lock bars.

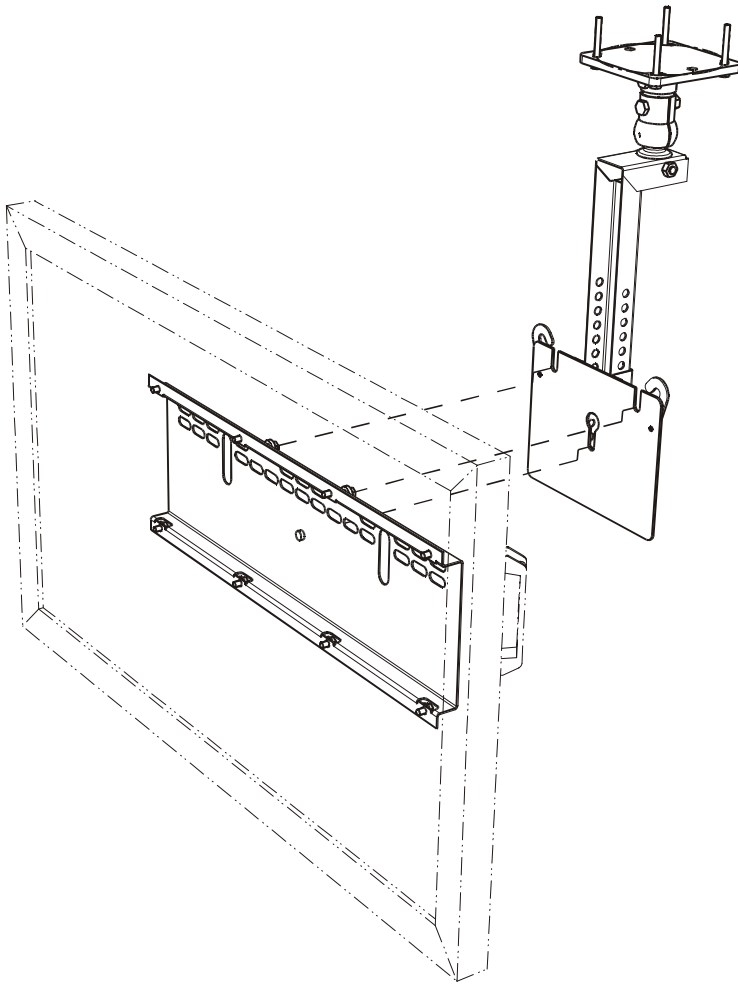

12.6.3 Dimensions

The following pictures give an overview about the measurements and dimensions of the 42" version and the 47".

12.6.3.1 Dimensions of the 42" version:

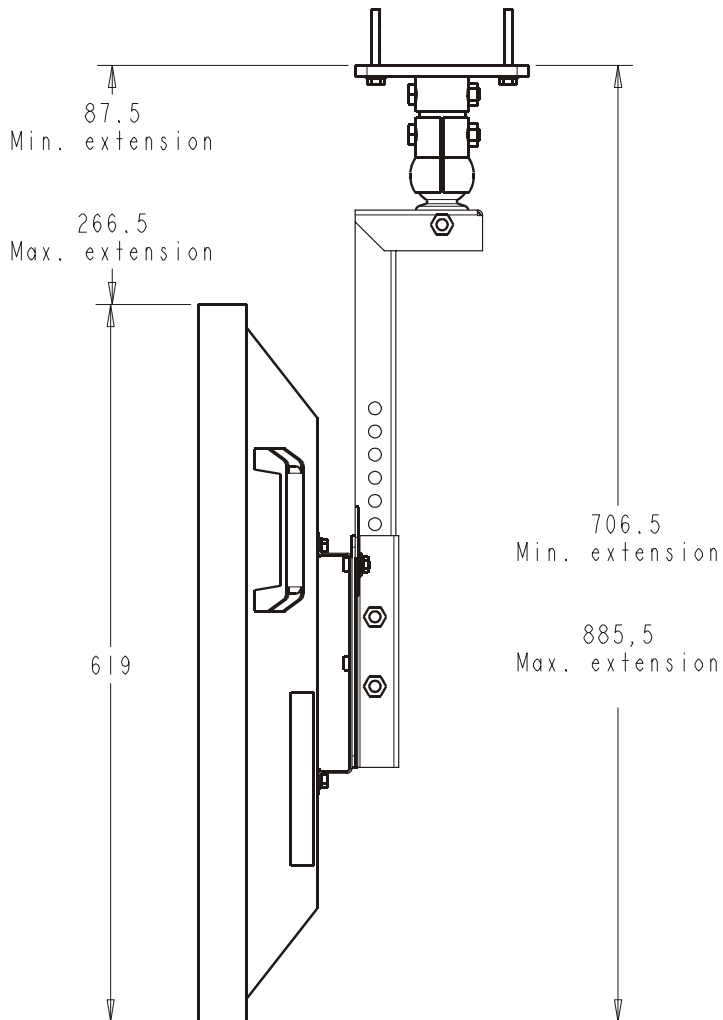

12.6.3.2 Dimension of the 47" version:

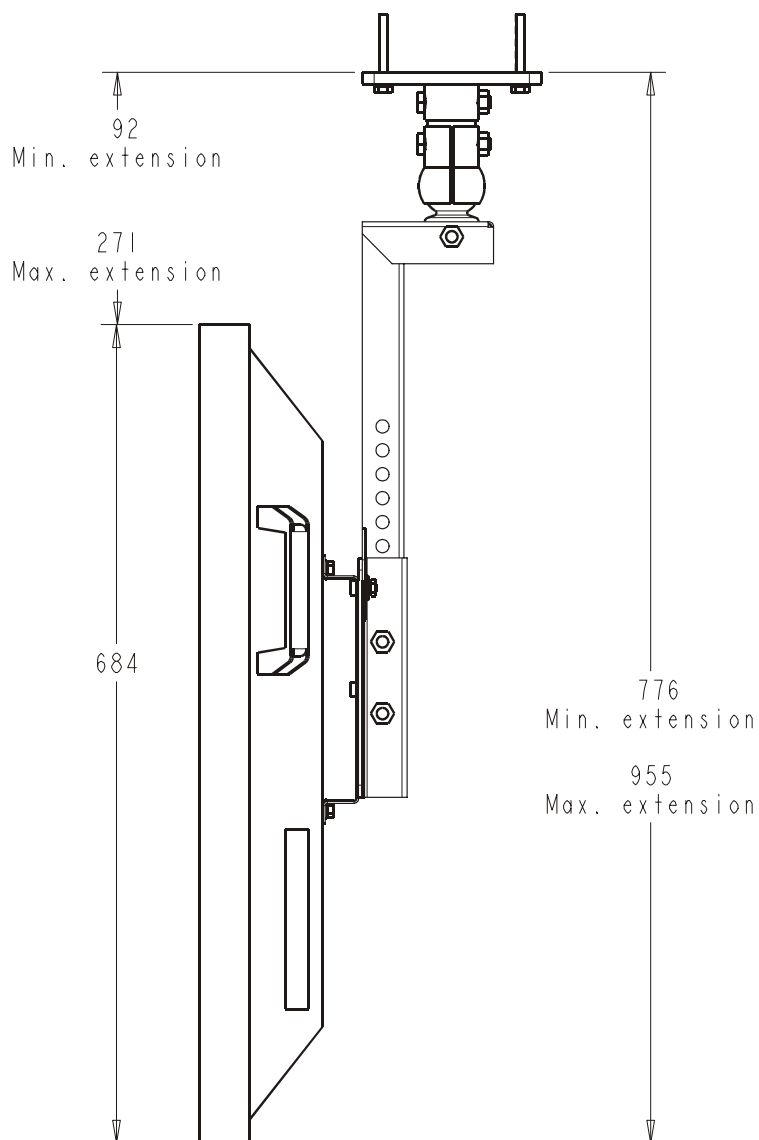

12.6.4 Tilting

Use an allen wrench size 2.5mm!

To adjust the tilting angle of the monitor,

- loosen the tilt angle fixation screw,
- adjust the position,
- tighten the screw again.

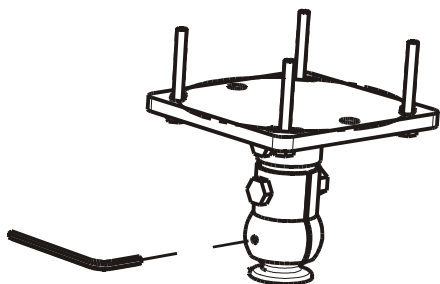

12.7 Long ceiling mount



First mount the screen bracket to the monitor, cf. [Screen bracket \(adapter plate\)](#)

The long ceiling mount fixes the monitors to the ceiling and allows setting the lower screen edge to a distance of the ceiling between 1235.5mm and 1614.5mm for the 42" versions, and between 1305mm and 1684mm for the 47" versions, respectively.

The monitors can be tilted by 20 degrees thanks to the ball point connection.

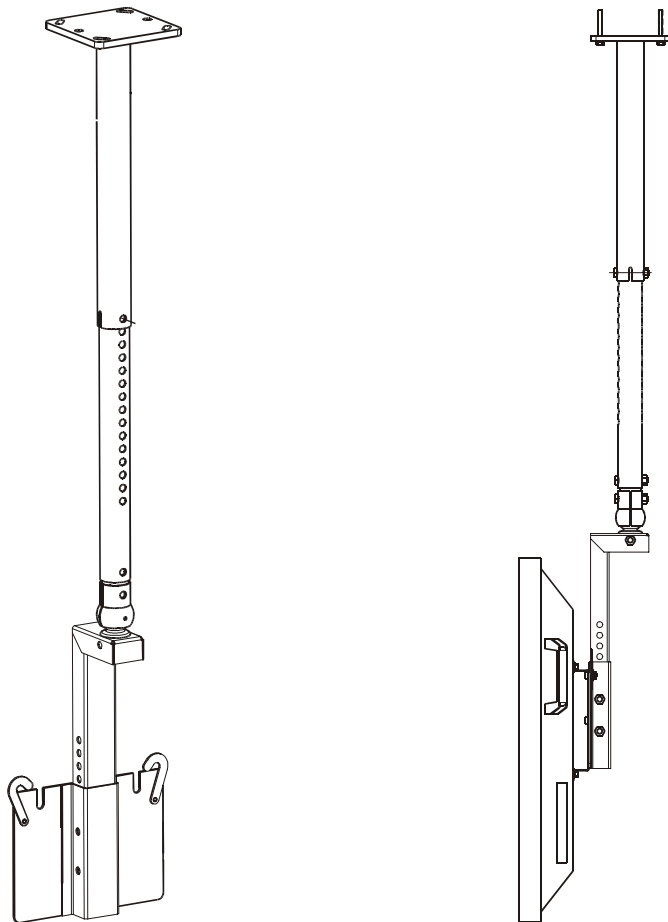

12.7.1 Scope of delivery

The short ceiling mount comprises 4 parts:

- The base plate with the cylinder which holds the telescope bar. This base plate will be mounted on the ceiling
- The telescope bar with the ball point connection to adjustable bar.
- The base plate with the ball point connection to the adjustable bar. This base plate will be mounted on the ceiling
- The adapter plate to attach to the screen bracket of the monitor with two hooks to lock the knurled bolts.

The screws to assemble the long ceiling bar are included. You will need a wrench 17mm.

The screws to fix the base plate to the ceiling have to be provided on site, cf. [Required tools](#).

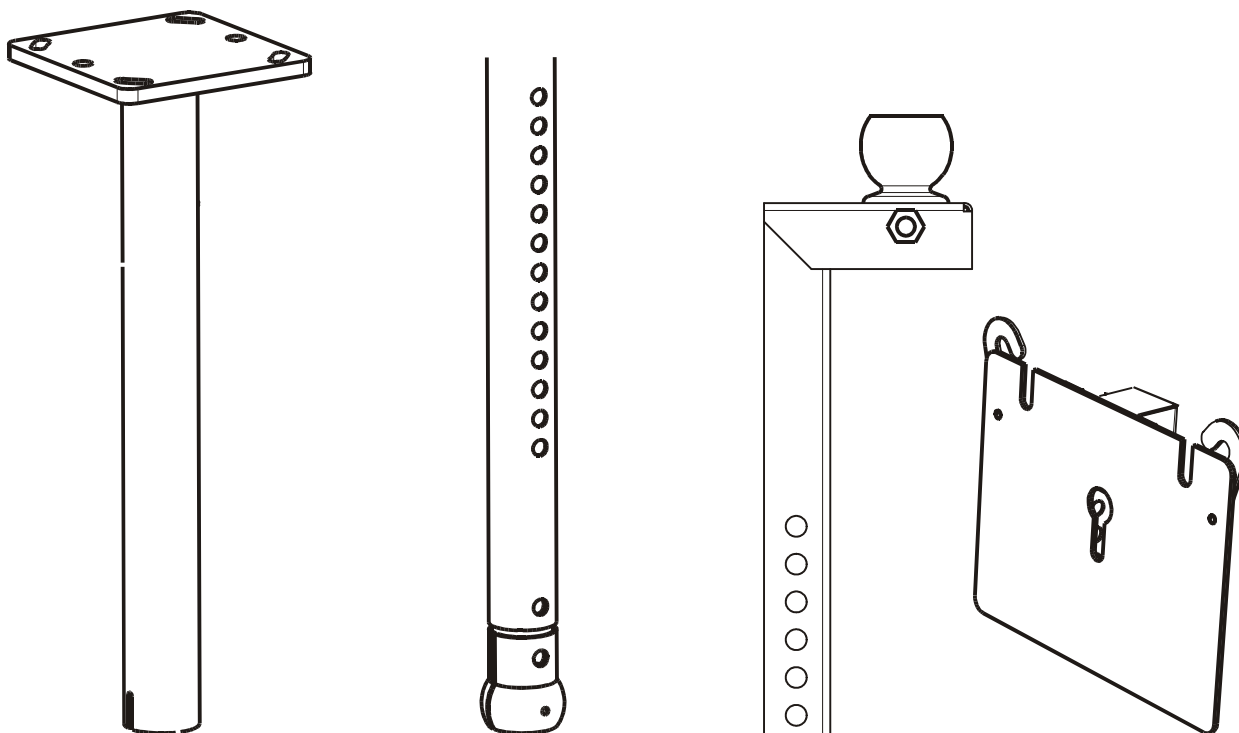

12.7.2 Installation

The wall mount bracket is attached to the wall by means of 4 screws M8 (for specification of the screws, cf. [Required tools](#)). It is the same bracket for 42" and 47".



For drilling the holes in the ceiling, it is recommended to use a jig – take a sheet of paper (A4) and copy the distances given in the drawing below.

- Drill 4 holes, 10mm, to the ceiling in the given distances!

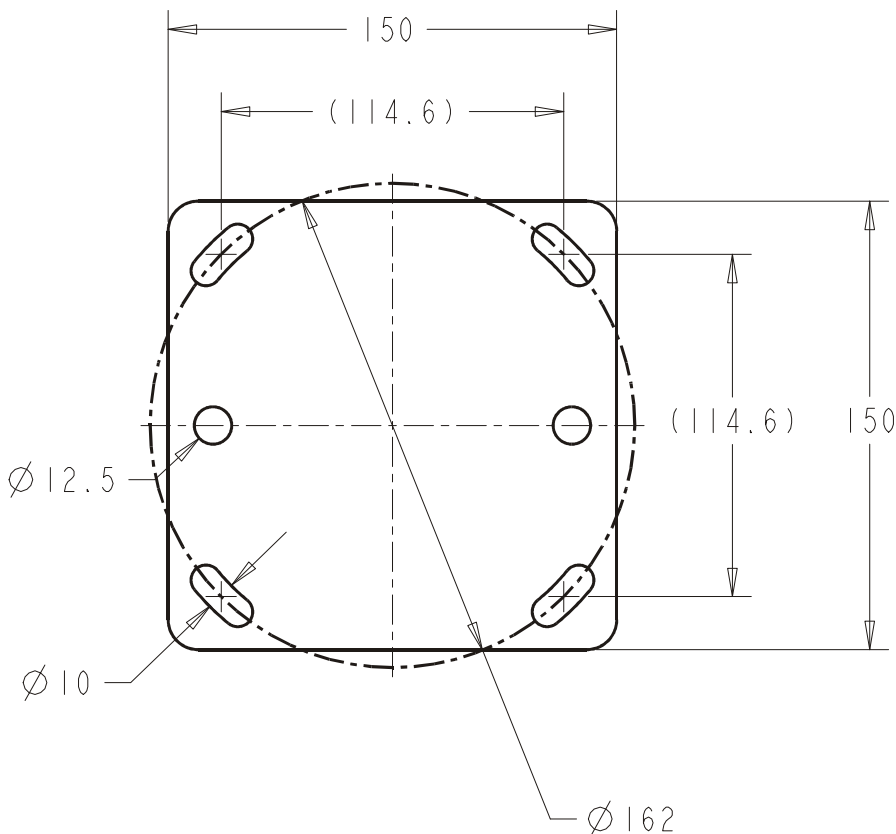

- Attach the ceiling mounting plate.
- Slid in the telescope bar and lock its position by means of a screw M10x60. Secure the screw with a nut, and apply the black plastic cap.
- Complete the ball point connection between the telescope bar and the adjustable bar by using one of the included screws M10x60. Secure the screw with the nut and attach the black plastic cap. Also attach a black plastic cap to the already installed parallel screw on the telescope bar.
- Slide in the adjustable bar into the monitor mounting plate of the long ceiling mount. Fix its position by one of the included screws M10x60. Secure the screw with the nut and attach the black plastic cap.

- Hook in the knurled bolts of the monitor into the notches and the keyhole of the long ceiling adapter plate. Lock the monitor by means of the left and right hook.

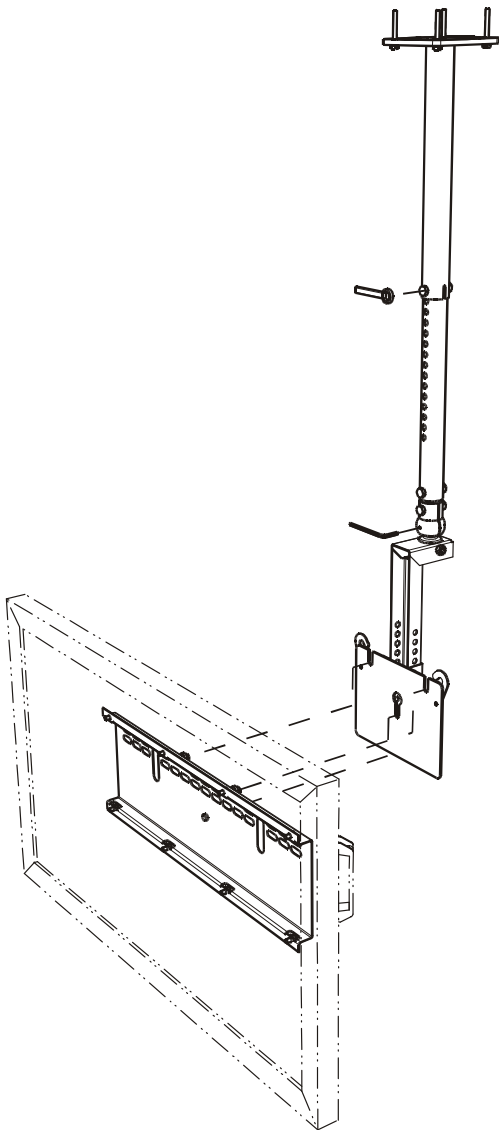

12.7.3 Dimensions

The following pictures give an overview about the measurements and dimensions of the 42" version and the 47".

12.7.3.1 Dimensions of the 42" version:

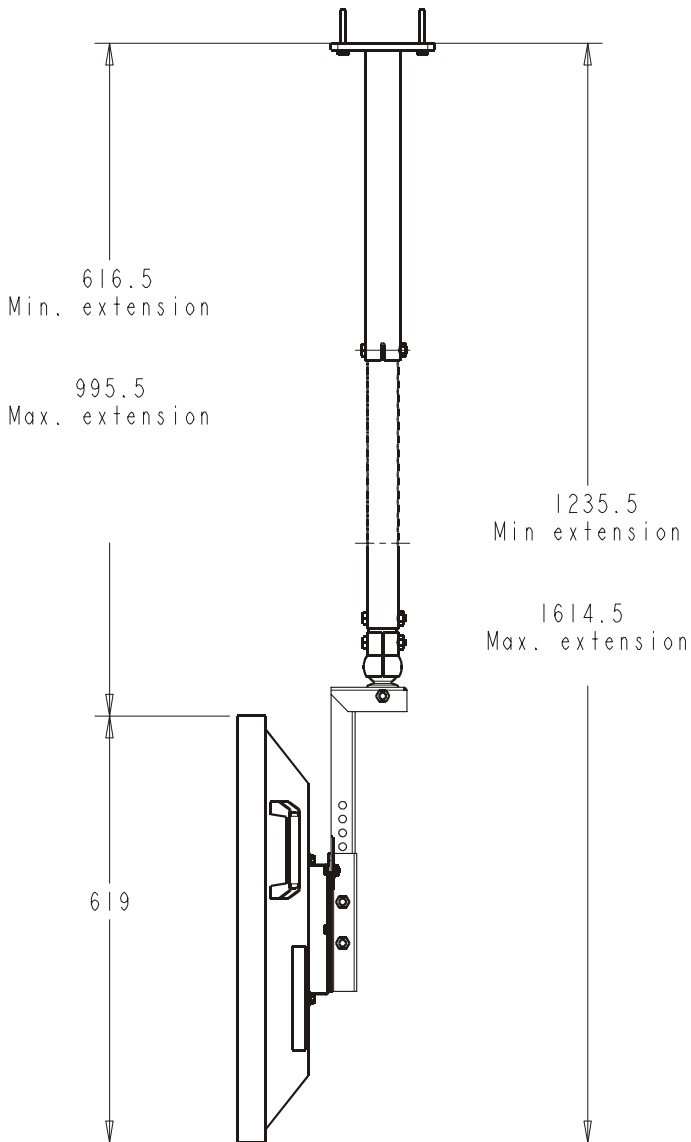

12.7.3.2 Dimension of the 47" version:

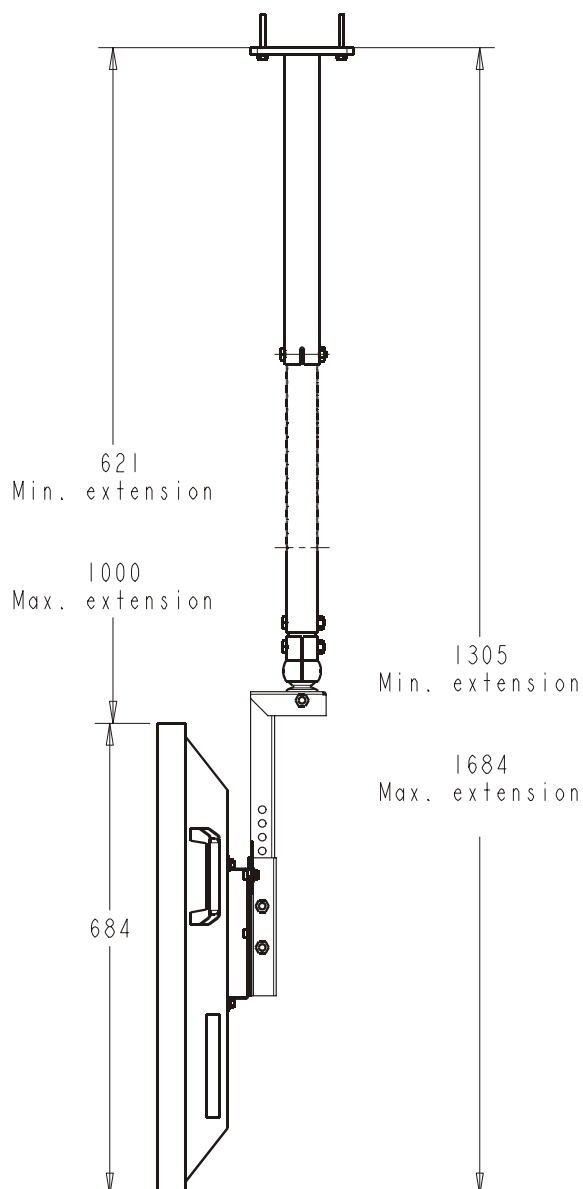

12.7.4 Tilting

Use an allen wrench size 2.5mm!

To adjust the tilting angle of the monitor,

- loosen the tilt angle fixation screw,
- adjust the position,
- tighten the screw again.

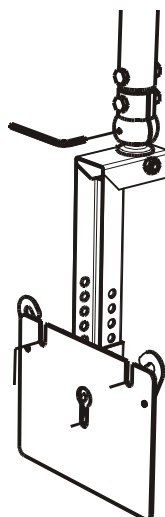

13 Contact

Feel free to contact us if you have any further questions!

- **Barco Control Rooms GmbH**
An der Rossweid 5 • D-76229 Karlsruhe • Germany
Phone (49) (721) 6201-227 • Fax (49) (721) 6201-298
E-mail support.de.bcd@barco.com, Web www.barcocontrolrooms.de
- **BARCO N.V.**
President Kennedypark 35 • B-8500 Kortrijk • Belgium
Phone (32) (56) 36-8282 • Fax (32) (56) 36-82 51
E-mail support.controlrooms@barco.com, Web www.barcocontrolrooms.com
- **BARCO N.V. Media**
Noordlaan 5 • B-8520 Kurne • Belgium
Phone (32) (56) 36-8970 • Fax (32) (56) 36-8386
E-mail media@barco.com, Web www.barco.com

